



Broad Agency Announcement

**Component, Context, and
Manufacturing Model Library - 2
(C2M2L-2)**

**Tactical Technology Office
DARPA-BAA-12-30**

February 24, 2012

- **Federal Agency Name** – Defense Advanced Research Projects Agency (DARPA), Tactical Technology Office (TTO)
- **Funding Opportunity Title** – Component, Context, and Manufacturing Model Library – 2 (C2M2L-2)
- **Announcement Type** – Initial announcement
- **Funding Opportunity Number** – DARPA-BAA-12-30
- **Catalog of Federal Domestic Assistance Numbers (CFDA)** – Not applicable
- **Dates**
 - Posting Date – 2/24/12
 - Proposal Due Date – 04/24/12
 - BAA Closing Date – 08/24/12
- **Total amount of money to be awarded** – Up to \$15 million
- **Anticipated individual awards** – Multiple awards are anticipated
- **Types of instruments that may be awarded** – Procurement contract or other transaction
- **Agency contacts**
 - LTC Nathan Wiedenman, Program Manager, DARPA/TTO
 - Christopher Glista, Contracting Officer, DARPA/CMO
 - E-mail: DARPA-BAA-12-30@darpa.mil
 - Fax: +1-703-248-8002

For all proposals to be received prior to April 30, 2012
 DARPA/TTO
 Attn: LTC Nathan Wiedenman, DARPA-BAA-12-30
 3701 North Fairfax Drive
 Arlington, VA 22203-1714

For all proposals to be received on or after April 30, 2012
 DARPA/TTO
 Attn: LTC Nathan Wiedenman, DARPA-BAA-12-30
 675 North Randolph Street
 Arlington, VA 22203-2114

TABLE OF CONTENTS

Section I: Funding Opportunity Description.....	4
Section II: Structure of Award.....	18
Section III: Proposal Requirements.....	28
Section IV: Proposal Evaluation Criteria.....	33
Section V: Eligibility Information & Additional Requirements.....	35
Appendix 1: Philosophical Underpinnings of Adaptive Vehicle Make.....	40
Appendix 2: Depiction of the META-iFAB Integrated Tool Chain.....	51
Appendix 3: META Package Example.....	53
Appendix 4: Model Curation.....	56
Appendix 5: Component Model Example.....	63
Appendix 6: Context Model Example.....	67
Appendix 7: Manufacturing Process Model Example.....	70
Appendix 8: Open Source License for AVM Software, Models, and Data.....	80

I. FUNDING OPPORTUNITY DESCRIPTION

Background

DARPA's Adaptive Vehicle Make (AVM) portfolio of programs is aimed at compressing at least five-fold the development timelines for new complex cyber-electro-mechanical systems such as military vehicles.¹ Under AVM, DARPA is pursuing the development of several elements of enabling infrastructure aimed at radically transforming the systems engineering/design/verification (META²/META-II³), manufacturing (iFAB⁴), and innovation (vehicleforge.mil⁵) elements of the overall "make" process for delivering new defense systems or variants. Each of these infrastructure capabilities is largely generic, i.e., applicable to any cyber-electro-mechanical system.

In order to exercise these capabilities in the context of a relevant military system, DARPA intends to build FANG⁶ – the Fast, Adaptable, Next-Generation Ground Vehicle – a new heavy infantry fighting vehicle (IFV). FANG's functional requirements will mirror those for the Marine Corps' Amphibious Combat Vehicle (ACV). A series of three design challenges focused on subsystems of increasing complexity will ultimately result in the FANG vehicle being built in the iFAB Foundry.⁷

The present Component, Context, and Manufacturing Model Library 2 (C2M2L-2, pronounced "camel 2") solicitation is for the second round of domain-specific models needed to enable the design, verification, and fabrication of the chassis and survivability subsystems of the FANG vehicle using the META, iFAB, and vehicleforge.mil infrastructure. (The first of these challenges is focused on the mobility and drivetrain subsystems, and is supported by the C2M2L-1⁸ effort.) A subsequent C2M2L solicitation is expected to address all of the remaining subsystem domains needed to construct and verify a complete infantry fighting vehicle.

The ongoing META program is on track to deliver an integrated capability for: compositional design synthesis at multiple levels of abstraction; design trade space exploration and metrics assessment with structural and information-based metrics of system complexity; formal semantic integration of models across multiple physical and cyber domains; and probabilistic verification of system correctness with respect to

¹ See Appendix 1 for a detailed overview of the portfolio and its philosophical underpinnings.

² <https://www.fbo.gov/spg/ODA/DARPA/CMO/DARPA-BAA-10-21/listing.html>

³ <https://www.fbo.gov/spg/ODA/DARPA/CMO/DARPA-BAA-10-59/listing.html>

⁴ <https://www.fbo.gov/spg/ODA/DARPA/CMO/DARPA-BAA-11-20/listing.html>, and <https://www.fbo.gov/spg/ODA/DARPA/CMO/DARPA-BAA-12-14/listing.html>

⁵ <https://www.fbo.gov/spg/ODA/DARPA/CMO/DARPA-BAA-11-21/listing.html>

⁶ <https://www.fbo.gov/spg/ODA/DARPA/CMO/DARPA-BAA-12-15/listing.html>

⁷ So termed in a nod to integrated circuit foundries that are comparably flexible manufacturing facilities.

⁸ <https://www.fbo.gov/spg/ODA/DARPA/CMO/DARPA-BAA-11-47/listing.html>

realistic context models using model checking and simulation traces. This capability will be embodied in several end-to-end tool chains ranging from a free, open source set of tools; to a mass-market, web-based, cloud-hosted capability; to a high-end commercial tool suite based around existing computer-aided design/product lifecycle management (CAD/PLM) products.⁹

The META design flow relies on composing designs from a library of detailed component models described using a formal metalanguage and which characterize in totality the interactive behavior of their subject components and the uncertainty thereof. These component models are the subject of Technical Area 1 (TA1) of this solicitation. A META design, once composed, can be verified against a set of environment or context models that characterize relevant operational scenarios, thereby yielding first-order estimates of vehicle performance. Such context models are the subject of Technical Area 2 (TA2) of this solicitation.

Once a winning design is selected following each FANG Challenge, the complete technical data package for that design will be forwarded to the iFAB Foundry performer. A largely automated process will then commence to develop a product flow and configure the distributed manufacturing network to support the product build. This would be followed by the automated generation of computer numerically controlled (CNC) instruction sets for each piece of manufacturing equipment, as well as instruction cards for human workers and associated training modules. In order to accomplish these tasks, each constituent element of the manufacturing process – whether it be a machine, process, or human – must have a corresponding model detailing its range of capabilities and other attributes. Generating such a manufacturing model library for fabrication of chassis/survivability systems is the subject of Technical Area 3 (TA3) of this solicitation.

Detailed Description of FANG Chassis/Survivability Challenge

The general scope of this challenge encompasses: hull, chassis, frame/panels or monocoque structure, modular armor panels, mountings/inserts, subsystem volumetric compartment placeholders, crew compartment with crew accommodations such as seats and restraints, subsystem mounting placeholders, hull penetrations for drivetrain/grills/ hatches, hatches, and blow-out panels. The final manufactured version of the winning design will be tested using industry-standard complete coordinate measurement dimensional metrology approaches, fit checks, corrosive and environmental effects, and survivability testing for kinetic penetration and blast effects. Consequently, for the purpose of requirements development and the ability of META

⁹ See Appendix 2 for a detailed overview of the META tool chain capability. A demo of one of the current META tool chains can be found at <http://cps-vo.org/avm/metax/video> in the form of a short screen capture video. Note that this is a snapshot of capability as it currently stands, pending additional maturation effort.

tools to synthesize correct-by-construction chassis/survivability designs, component and context models corresponding to all of these test parameters will be developed by the C2M2L-2 performers and made available to the FANG challenge participants. The prize award for the winner of this challenge will be \$1 million, awarded directly by DARPA. A single copy of the winning design will be manufactured by the iFAB Foundry.

Program Overview

The period of performance for awards under this BAA will be 12 months from the date of award. Proposers may submit proposals to one, several, or all of the technical areas detailed below. Although the technical areas are clearly interrelated, Proposers are encouraged to submit separate proposals for each one or include them as priced options to their core proposal so as to enable the Government to easily fund a subset of the proposed effort.

Although the ultimate goal of the AVM portfolio is to culminate in a FANG vehicle, i.e., a complete heavy and potentially amphibious infantry fighting vehicle, the specific scope of the present C2M2L-2 BAA is the chassis and survivability subsystems for a heavy infantry fighting vehicle with amphibious considerations. This is the second of three prize challenges that will focus on this specific subset of the overall vehicle design problem. Since the C2M2L-2 model libraries must be able to support a wide assortment of possible designs, this BAA does not specify the precise contents of the chassis and survivability subsystems.

Items to be considered within scope of the chassis and survivability subsystems include hull, chassis, frame/panels or monocoque structure, modular armor panels, mountings/inserts, subsystem volumetric compartment placeholders, crew compartment with crew accommodations such as seats and restraints, subsystem mounting placeholders, hull penetrations for drivetrain/grills/hatches, hatches, and blow-out panels.

It is also noteworthy that the definition of a component and context for the purposes of this BAA is multi-scale. The ultimate goal of the AVM portfolio is to characterize a substantial “catalog” of military ground components at the individual numbered part level (as commonly utilized in vehicle designs and industry-standard drawing trees). The META design tools, however, are meant to support design synthesis at multiple levels of abstraction and multiple scales. Thus, certain tightly-integrated and infrequently-altered sub-assemblies and assemblies may be more efficiently treated as a single entity – versus an aggregation of components – within the model library. Proposers may propose model development and representation at any scale or abstraction level, but should justify their choice if it is not at the lowest-numbered-part level.

The multi-scale notion applies analogously to context models. The principal thrust of this BAA in this regard is on the development of overall environment models (e.g., shock and vibration, atmosphere including thermal and marine environments, kinetic/blast effects, etc.) affecting chassis and survivability subsystems. In addition to overall environment models, there is a need for context environmental models at finer scales to address how the vehicle components interact with their local environment. This includes interior to the vehicle, exterior to the vehicle (which may include marine environments and storage) as well as environmental interaction between vehicle components. For example, components of dissimilar materials may face significant corrosion issues in a saltwater environment. (It is important to note that component models can and will be used as context models for other components in many cases.)

And finally, manufacturing models may also be generated at multiple scales. For example, the particular characteristics and range of operating capabilities of a composite fiber placement machine might be of interest. Similarly, the entire composite manufacturing process (including fiber placement, autoclave, and post-processing) for a given class of materials and geometries might instead be characterized as a single manufacturing model. Both are of interest and proposers should justify their proposed approach. Note that in cases where models have the potential to be redundant (i.e., they might subsume the same component(s) at varying levels of fidelity and abstraction), proposers should propose an appropriate linking scheme.

Much of the data needed to create component, context, or manufacturing models already exists in the form of data sheets, spec sheets, catalogs, existing simulations, and in the literature. Proposers are encouraged to use such data to their advantage in their proposed C2M2L-2 efforts. However, proposers are cautioned in the strongest possible terms to be mindful of “contaminating” the intellectual property posture, i.e., the objective of open-source model dissemination and Unlimited Rights to the Government, of their deliverables (more on this in the Deliverables section below).

Performer contracts awarded under this BAA will execute concurrently with the C2M2L-1, FANG, and iFAB Foundry performers (awarded under separate BAAs). A significant amount of data sharing, integration, and adaptation will be required in order to ensure synchronization, compatibility, and harmonization of the deliverables. Proposers are encouraged to structure their proposals accordingly, such that reasonable adaptation in the course of execution can be accomplished without contractual modifications.

DARPA recognizes that there is significant leeway in the scope of effort that can be proposed under this BAA. This is done intentionally to accommodate the widest possible range of proposers and ideas. It also necessarily introduces uncertainty in proposal development. Proposers are therefore encouraged to structure their proposals

in a flexible manner, such that scope changes can be effected in the course of contract negotiations without the need for proposal resubmission (e.g., through modular cost proposals or inclusion of contract options executable at award time).

The software tools, documentation, specifications, and sample models being produced under the META, iFAB, and vehicleforge.mil efforts are being developed as open-source software, licensed in accordance with the open-source license in Appendix 8 to this BAA. Complete visibility into these products and their ongoing development will be afforded to the C2M2L-2 performers.

DARPA recognizes that the metalanguage specification developed and being refined under the META program and associated follow on efforts is key to the representation of component and context models to be developed under TA1 and TA2. Similarly, the manufacturing model specification being developed under the iFAB program is essential to the representation of data assembled under TA3. While these individual efforts are incomplete, they are mature enough to form the basis of effort under this BAA. DARPA expects and encourages collaboration with relevant performers during execution of any award by holding bi-monthly principal investigator (PI) meetings. These existing efforts are converging on Modelica as the native format for model representation, and therefore this is preferred for C2M2L-2 deliverables. If a proposer has a significant technical or cost-based reason to propose models in a format other than Modelica, they must substantiate and justify their decision to do so. This does not preclude the potential selection of this proposer and the subsequent utilization of their models, however, as the ability to translate models between formats exists within the META and C2M2L curation work currently underway.

Proposers should plan to participate in regular AVM portfolio-wide PI meetings (to include other C2M2L-2 performers) and be prepared to share deliverables, progress, status, and challenges in this forum, as well as assimilate ideas from other performers into their execution strategy (more on PI meetings in the Deliverables section below).

This BAA is intentionally structured in the form of multiple independent technical areas to facilitate participation by small and non-traditional performers, as well as academic and other not-for-profit institutions. Proposers may respond to only those technical areas that are within their scope of competency and capability. Teaming is neither required nor encouraged. International participation in this solicitation is welcome (see additional information relating to export control in the Deliverables section below).

Note that all models and associated services, tools, etc. developed under C2M2L-2 must be rigorously documented such that a third party, independently of the authoring performer, should be able to fully utilize, modify, update, refine, and maintain the model library.

Technical Area One: Component Model Library

The component model library will be a database of a substantial number of component models relevant to the chassis and survivability subsystems of a heavy infantry fighting vehicle. This is to include but is not limited to: hull, chassis, frame/panels or monocoque structure, modular armor panels, mountings/inserts, subsystem volumetric compartment placeholders, crew compartment with crew accommodations such as seats and restraints, subsystem mounting placeholders, hull penetrations for drivetrain/grills/ hatches, hatches, and blow-out panels. Weapons will not be designed/modeled, however, provisions will be made for the size, weight, power, mounting of 'typical' infantry fighting vehicle external, mounted, and in some cases hull-penetrating systems (for example mounts capable of supplying power and supporting a range of weights and forces). Each component model will be an object which can be manipulated by the META design and verification tools. The component models will be aggregated into a viable design that can be computationally verified to be correct-by-construction. Further, its behavior and performance can be evaluated against a set of context models (at least probabilistically so, within the uncertainties of the component models, context models, and the exhaustiveness of the verification algorithm). This design and verification approach is loosely analogous to that employed in VLSI design and in model-based software design and automatic code generation, but generalized to a broad class of highly heterogeneous, large-scale, cyber-electro-mechanical systems (infantry fighting vehicles) that are strongly coupled to complex environments (terrain, etc.).

To enable this capability, a component model must completely characterize the modalities of interaction (and the associated dynamics) between a component and any other component in the system, as well as the environment. Thus, component models must be able to serve as context models for other components. They must also characterize the functional behaviors and performance, as well as any degradation thereof in response to changes in context or internal failure modes. Some of this data is well-understood and well-known today; it must simply be assembled, qualified, and its intellectual property status verified with respect to BAA requirements. This might include, for instance, the geometric shape, manufacturing geometry, mass properties, and the power and data interfaces of a given component. Other data, however, will likely require extensive characterization activities, such as the generation of thermal source maps, electromagnetic emissions, vibrational source characteristics, mapping performance and failure modes with respect to thermal or electromagnetic input, elastodynamic properties of non-structural components, etc.

For all except purely software components (which get the benefit of the digital abstraction), the empirical, analytical, or computational data used to generate the component model necessarily has some uncertainty associated with it vis-à-vis its real-world instantiation. This uncertainty must itself be carefully modeled and documented.

The ability to certify the correctness of system designs assembled from component models to a given probability of correctness depends on the accuracy of the constituent component models.

Proposers should also incorporate relational information in the component model. Such relational information may, for instance, determine the constrained relative motions of two components: they may be fastened together and move in lockstep; they may be connected by a hinge or a piston or a lever arm, each of which implies limited relative motions, etc. It may also include linkage between the same component represented at multiple different layers of abstraction. It may include relationships between components and applicable context models or manufacturing models.

Certain utility services for searching, manipulating, and translating models should be developed to aid in the utilization and maintenance of the component model library. And finally, data sources as well as verification & validation (V&V) methods and history should be documented for each component model.

The key elements sought in a component model are summarized below:

- Physical attributes
 - Outer mold-line
 - Mass properties
 - Elastodynamic properties
 - Static and dynamic load bearing as structural components
- Desirable interactions with other components & environment
 - Mechanical interface & structural load-bearing characteristics
 - Data interface
 - Power interface
- Undesirable interactions with other component & environment
 - Thermal source and sink characteristics
 - Electromagnetic source and sink characteristics
 - Vibrational source and sink characteristics
 - Acoustic source characteristics
 - Effect of moisture, humidity, corrosives, and particulates (particularly the sea-going salt-water environment)
 - Sealing (or failure to seal) characteristics
 - Effects of kinetic impact and blast interactions on structure and human occupants
- Performance
 - Black-box performance model

- Failure modes, performance limits, and behaviors (i.e., effect on other model parameters)
- Uncertainties
 - Error bounds on each model data element
 - Probability distribution of model data uncertainties
 - Uncertainty in shape of probability distributions
- Relational information
 - To “peer” components (e.g., dependencies)
 - To self at other levels of abstraction
 - To context models
 - To manufacturing models
- Services
 - Version control and tracking
 - Indexing and search
 - Model translation
- Supporting model data
 - Model data sources
 - V&V methods, history, and results
 - Cost, lead-time, manufacturability

It is worthy of amplification at this juncture that components can be hardware or software entities.

Component models should be supplied in a suitable domain-specific or multi-domain modeling language with well-defined, formal semantics. The choice of language must be such that:

- Its constructs and operations are well-defined
 - Users can prove that model constructs and properties are legal expressions of the modeling language
 - It has clean, explicit support for interfacing (e.g., APIs or other integration methods) with other modeling languages and analysis tools
- It is supported by formal (mathematically-based) semantics
 - Users can prove that all necessary model input data, functions, and constraints lead to appropriate model constructs and properties that are interpretable within the modeling language
 - Models are composable such that properties can be formally derived and proven about appropriate constructions of a plurality of components

- Users can prove that model constraints and conditions are met and that desirable states are reachable and undesirable states avoidable

Proposers should thoroughly justify their choice of modeling language and discuss its properties vis-à-vis the characteristics noted above.

Analysis of both military and commercial vehicles indicates that the chassis and survivability systems comprise on the order of 5000 unique components with some vehicles having as many as 7000 unique components. In order to allow for vehicle sizing and significant design degrees of freedom, a component model library of at least 5-10 times this number of components is sought. As noted above, however, while the ultimate goal is to build the full library at the individual numbered part level, the META design tools are meant to support design synthesis at multiple levels of abstraction and multiple scales. Thus, for instance, certain tightly-integrated and infrequently-altered sub-assemblies and assemblies may be more efficiently treated as a single entity – versus an aggregation of components – within the model library. Proposers may propose model development and representation at any scale or abstraction level, but should justify their choice if it is not at the lowest-numbered-part level. The inclusion of military grade or MILSPEC components is encouraged; however, component models need not be limited to domestically-sourced components.

The expectation for the scope and type of models for this effort encompasses the chassis, hull, survivability systems, and all components that would reside within the vehicle or be necessary for its operation. This includes but is not limited to:

Crew Compartment: operator and passenger seating and restraints, operation controls, HVAC systems, provisions for communication and other electronics mounting, ingress and egress capabilities, equipment stowage, hatches with attachments and opening mechanisms

Internal systems: Routing for hydraulics, electrical, airflow and filtration, as well as subsystem mounting placeholders

External systems: Mounting, structure and fasteners to support external mounted armor, turrets, drivetrain elements, and all associated control systems, modular armor, hull pass-throughs (for drivetrain elements, grills, hatches, blow-out panels, etc.)

Rigorous model documentation should be produced as part of any proposal to this technical area.

Technical Area Two: Context Model Library

Context models provide information about the environment within which a system, subsystem, or component must function. In other words, context models must also apply across the different levels of abstraction. At the component level, the most important contexts are provided by other components (said differently, inter-component interactions dominate external influences), whereas at the overall system level (by definition) the principal interaction or context is the mission environment.

The principal focus of this technical area is on exogenous contexts applicable at all levels of abstraction to chassis and survivability subsystems of an amphibious infantry fighting vehicle. The overall hull chassis, armor, crew compartment, weapons, etc. themselves form a context, within the scope of this technical area. Since the hull, chassis, armor, and associated subsystems are the subject of this C2M2L-2 BAA, context models must include the possibility of impact with the terrain or other fixed or mobile objects. It is impossible to predict the impact size, speed, location or direction at this time, so the context models will need the ability for user input of shock, vibration and damage profiles defined at a later date.

Of specific interest under this technical area are context models needed to define survivability performance of the chassis and modular armor as exposed to direct fire, indirect fire, and mine/IED threats.

Infantry fighting vehicles on the modern battlefield must be capable of surviving significant underbody blast (as evidenced by the IED threat in both the Iraq and Afghanistan theaters of operations), as well as impact from high velocity kinetic and high explosive ballistic threats. In order to adequately evaluate candidate designs for the FANG challenges with respect to these requirements it is necessary to instantiate context models that represent these events and enable characterization of system responses under these types of loading. Proposers should be specific with regard to the tools being utilized to instantiate the blast and ballistic impact context models (LS-DYNA, AMANDA, MUVES-S2, etc.)

It is important to re-emphasize at this point that the intent of AVM is to remain entirely open and unclassified. Therefore, it is vital that proposers understand the division between classified and unclassified in the realm of blast and impact modeling. Models that represent blast and ballistic threat characteristics are not classified unless they are explicitly tied to evaluation of a specific armor or survivability package. Since this solicitation does not require armor or survivability package information, the context models needed are viewed as unclassified.

Vehicle interior environments include local environments (temperature, humidity, electro-magnetic interference, etc.) around the motor/drivetrain, in the electronics, and crew compartments. This will permit designing for both vehicle mission (electronics and equipment survivability, etc.) and crew comfort/endurance.

For all but the simplest contexts and phenomena, the empirical, analytical, or computational data used to generate the context model necessarily has some uncertainty associated with it vis-à-vis its real-world manifestation. This uncertainty must itself be carefully modeled and documented. The ability to certify the correctness of system designs to a given confidence level with respect to a particular set of context models is strongly dependent on the uncertainty in these models.

Certain utility services for searching, manipulating, and translating context models should be developed to aid in the utilization and maintenance of the model library. And finally, data sources as well as verification & validation (V&V) methods and history should be documented for each context model.

Rigorous model documentation should be produced as part of any proposal to this technical area.

Technical Area Three: Manufacturing Model Library

The manufacturing model library enables the iFAB tool-set to design a new foundry capable of fabricating a given range of products and product variants, configure an existing foundry design by generating a product flow as well as CNC and human instructions for manufacturing a specific design, and feed back the range of feasible designs that a particular foundry can support as a constraint on the product design trade space within the META tool-set.

A manufacturing model characterizes a particular element of the foundry – a machine, a process, or a human – in terms of its capabilities, costs, and constraints and associations. A non-exhaustive list of manufacturing model characteristics and functions might encompass:

- Domain of applicability
 - Assembly
 - Mechanical
 - Electrical
 - Electronic
 - Structural
 - Hydraulic
 - Pneumatic
 - Metrology
 - QA/QC
 - Etc.

- Range of applicability

- Dimensions
- Tolerances
- Geometries
- Material types
- Speed
 - Speed
 - Product throughput
 - Reconfiguration time
- Cost
 - Consumables
 - Operation
- Quality
 - Defect rate
- Uncertainties
 - Error bounds on each model data element
 - Probability distribution of model data uncertainties
 - Uncertainty in shape of probability distributions
- Relational information
 - To product components (i.e. special fixtures)
 - To other manufacturing elements/processes (e.g., dependencies)
- Services
 - Version control
 - Indexing and search
 - Model translation

The majority of necessary static discrete manufacturing models are already being developed under existing efforts within iFAB and C2M2L-1. However, some modeling needs are yet to be addressed for the completeness necessary to execute the FANG challenges, in particular as applied to the chassis/survivability topic of this solicitation. The models identified as high priority are kinematic performance models and fixturing (both for machining and assembly).

Kinematic performance models of manufacturing are needed to ensure overall system success. Rather than simply a collection of static data (workspace envelope, machine geometry, power ratings, etc.), in order to fully inform the AVM design process a manufacturing process model must capture the physics-based characteristics of a machine/tool and its interactions with the work piece/material being operated on. This

includes but is by no means limited to cutting speeds and depths, material deposition or removal characteristics, frequency response characteristics (to include chatter), and predicted wear. Associated uncertainties are required for these characterizations.

Fixturing of components for machining and assembly is also critical. Fixture points, forces, and order need to be determined to ensure a part or assembly can be made as required with resources available. These fixturing characteristics must be, to the extent practicable, automatically generated given a META data package with assembly liaison graph relationships, fastening specifications, and tolerances included. Models of standard fixtures and their capabilities are desired for inclusion in the model library, along with the capability to provide basic design feedback in the form of recommendations for special or unique fixtures.

Additional modeling needs include:

- Material Removal
 - Grinding
 - Machining
- Forming and Shaping
 - Swaging (for example preparing hydraulic line fittings)
 - Soft hose forming (for example for custom liquid cooling routing)
- Machine Assembly
 - Hard Automation
 - Positioning – part presentation
 - Aligning
 - Sorting
 - Transport
 - Dithering for insertion
- Fixturing
 - For welding large hull components as well as small elements
 - For subsystem assembly
- Permanent Joining and Assembly
 - Welding (multiple types)
 - Pressing
 - Crimping
- Human Operations
 - Disassembly
 - Inspection
- Finishes

- Acid washing, electroplating
- Painting (CARC and other)
- Inspection and Metrology
 - Dynamic testing
 - Polishing
 - Pressure testing
- Electrical and wiring
 - Brackets and other methods of securing

Rigorous model documentation should be produced as part of any proposal to this technical area.

As with the component model library, the manufacturing model library is a catalog construct, i.e., it will contain a significant superset of the actual manufacturing equipment needed to instantiate a particular iFAB foundry, and should be structured to allow additions and extensions to it.

II STRUCTURE OF AWARD

Award Instrument

DARPA anticipates making multiple awards under this BAA. The amount of resources made available under this BAA will depend on the quality of the proposals received and the availability of funds. DARPA tentatively anticipates making up to \$15.0 million available for multiple awards across all technical areas.

The awards will be either a procurement contract or, where deemed necessary and where appropriate statutory conditions are met, an other transaction agreement (OTA).¹⁰ The procurement contract may either be a cost plus fixed fee (CPFF) instrument (or cost plus zero fee in cases where the performer is a non-profit entity) where the awardee has a Defense Contract Audit Agency (DCAA)-approved cost accounting system or a firm fixed price (FFP) instrument in cases where the awardee does not have an approved accounting system, has a preference for an FFP contract, or where the Contracting Officer deems it appropriate. In cases where an FFP contract is utilized, payments may be conditioned on periodic deliverables such as monthly reports so as not to increase the performance risk borne by the awardee versus a CPFF instrument.

The Government reserves the right to select for negotiation all, some, one, or none of the proposals received in response to this solicitation, and to make awards without discussions with proposers. The Government also reserves the right to conduct discussions if it is later determined to be necessary. Additionally, DARPA reserves the right to accept proposals in their entirety or to select only portions of proposals for award. In the event that DARPA desires to award only portions of a proposal, negotiations may be opened with that proposer. The Government reserves the right to fund proposals in phases with options for continued work at the end of one or more of the phases.

Contract Deliverables & Reviews

Proposers should propose an appropriate schedule of deliverables and milestones in their statement of work (SOW) with dates indicated as relative values after contract award (ACA). That schedule should be congruent or constitute a superset of the

¹⁰ Proposers interested in receiving an OTA and where cost share is required are asked to submit proposal responses that accommodate both options. The government must be able to determine that the amount of the agreement is fair and reasonable and determine the final type of award to negotiate. Without complete cost volumes, it may not be possible to thoroughly understand what is being offered. For further information on OTAs, see: http://www.darpa.mil/Opportunities/Contract_Management/Other_Transactions_and_Technology_Investment_Agreements.aspx.

minimal deliverables outlined in Table 1 below. Written deliverables should generally take the form of reports in Adobe PDF format. Where appropriate, enclosures should include complete diagrams, schematics, data sets, models, algorithms, source code, object code, executable code, documentation, test/use cases, and hardware implementing the capability described in this BAA. Where feasible, a flat-file representation of the enclosed item should be included as an appendix to the PDF report. Draft versions of all deliverables (except hardware) should be supplied 30 calendar days prior to the deliverable due date.

Table 1: Technical Deliverables

Technical Area	Deliverable (format; timing)
TA 1 - Component Models	<ul style="list-style-type: none"> • Detailed IFV vehicle-level metrics and requirements (2 weeks ACA) • Detailed vehicle benchmarks (4 weeks ACA) • Initial market surveys detailing preliminary chassis and survivability subsystem technology (4 weeks ACA) • Component library inventory down-selection to develop a comprehensive list of component models to be included in the drivetrain library (6 weeks ACA) • Delivery of a point of departure set of models representing a small IFV chassis subsystem (e.g. structural system, crew seating, etc.) to show representative component model structure (8 weeks ACA) • Final market surveys detailing chassis and survivability subsystem technology (13 weeks ACA) • Delivery of partial models to provide a framework for interfaces and input/output requirements (26 weeks ACA) • Delivery of model set of a C2M2L-2 set of key subsystems and basic exercising of the models within a simplistic, performer provided context model (32 weeks ACA) • Delivery of final models and completion of component model libraries (46 weeks ACA) • Technical report detailing verification and validation for each model to ensure the accuracy of the component models and establish each model’s uncertainty characteristics (46 weeks ACA) • Technical documentation of libraries defining all inputs/outputs, limitations, verification/validation for each component, subsystem, or system architecture model (52 weeks ACA) • Component model final report (52 weeks ACA)
TA 2 - Context Models	<ul style="list-style-type: none"> • Demonstration and presentation of the first iteration of context models (10 weeks ACA) • Demonstration and presentation of initial context model library architecture and context model utility services (18 weeks ACA) • Demonstration and presentation of the second iteration of context models (26 weeks ACA) • Demonstration and presentation of pilot context model

	<p>library interaction, requirements development, and initial pilot design (26 weeks ACA)</p> <ul style="list-style-type: none"> • Demonstration and presentation of updated context model library architecture and context model utility services (36 weeks ACA) • Demonstration and presentation of the third iteration of context models (40 weeks ACA) • Demonstration and presentation of updated context model library interaction (40 weeks ACA) • Context model final delivery (52 weeks ACA) • Completion of utility services software and documentation of context model library architecture and context model utility services (52 weeks ACA) • Demonstration and presentation of final version of context model library interaction (52 weeks ACA)
TA 3 – Manufacturing Process Models	<ul style="list-style-type: none"> • Initial drivetrain foundry component models, model language, and semantics demonstration (8 weeks ACA) • Taxonomy for the range of foundry components that span the full spectrum of ground and amphibious combat vehicle chassis and survivability manufacture and assembly (16 weeks ACA) • Initial model population demonstration (16 weeks ACA) • Initial component model library demonstration (26 weeks ACA) • Final language demonstration (34 weeks ACA) • Component model library finalized (42 weeks ACA) • Final demonstration (52 weeks ACA) • Source files containing the model library and extensions (end of technical effort)
Final Reports	<ul style="list-style-type: none"> • Technical manuscript of publishable quality and suitable for publication in a journal or conference proceedings documenting performer’s technical progress and results achieved in significant detail, and • Programmatic final report containing financial data and other information not suitable for publication but appropriate for program documentation and planning (end of technical effort)

Additionally, certain periodic deliverables will be expected of the performer. These are summarized in Table 2 below. All deliverables except Monthly Financial & Hours Reports and where the protection of third-party proprietary or Privacy Act information requires otherwise, will be shared throughout the AVM performer community and will ultimately be publicly released where policy considerations and export controls allow. The Monthly Financial & Hours Reports must include the number of hours worked by contractually-identified key personnel in the preceding month. The key personnel hour amounts of these reports need not be auditable figures and may be informally gathered by the performer’s project manager. No draft versions of monthly or weekly deliverables are required; however, draft versions of the PI meeting presentations will be required one week in advance of the PI meeting.

Table 2: Periodic Deliverables

Periodic Reporting Items	Means of Delivery
Bi-Monthly Presentations and Demos at AVM PI Meetings	PI meetings at major U.S. metropolitan areas (open to all AVM PIs)
Monthly Technical Report	Sharepoint (open to all AVM PIs) and e-mail
Monthly Financial & Hours Report	Sharepoint (open to government only) and e-mail
Weekly Informal Progress Updates	Video or teleconference (30-45 mins avg duration)
Reports per Milestone/Deliverable	Sharepoint (access on case-by-case basis)

All milestone reviews will be conducted in the form of principal investigator (PI) meetings – occurring on a bi-monthly (every two months) cadence – at which all performers across the various technical areas and other AVM programs will be present. The PI meetings will be held at Government-furnished facilities in major domestic metropolitan areas with easy access by air. The Government reserves the option to make the PI meetings open events and invite non-performer organizations to attend if it is deemed in the Government’s interest to do so.

Intellectual Property & Data Handling

DARPA desires Unlimited Rights, as defined in DFARS 252.227-7013 and -7014,¹¹ to all deliverables generated by the performer(s) under this effort except clearly-identified, widely-available, commercial software tools, with their commercial availability described and substantiated in the proposal.

Additionally, the performer(s) should take affirmative steps for open source promulgation of all software, models, and documentation delivered under this effort. To this end, all software, models, and documentation should be licensed in accordance with the terms of Appendix 8 and incorporate the license text.

Although the status of individual vehicle component models and tech data packages vis-à-vis the International Traffic in Arms Regulations (ITAR) is currently under review by the government, it is likely that at least some IFV designs will fall within the scope of 22 CFR § 121, The United States Munitions List.¹² The following clause will be included in all procurement contracts, and may be included in Other Transactions as deemed appropriate:

(a) *Definition.* “Export-controlled items,” as used in this clause, means items subject to the Export Administration Regulations (EAR) (15 CFR Parts 730-774) or the International Traffic in Arms Regulations (ITAR) (22 CFR Parts 120-130). The term includes:

¹¹ <http://www.acq.osd.mil/dpap/dars/dfars/html/current/252227.htm#252.227-7013>

¹² http://www.pmddtc.state.gov/regulations_laws/documents/official_itar/ITAR_Part_121.pdf

1) "Defense items," defined in the Arms Export Control Act, 22 U.S.C. 2778(j)(4)(A), as defense articles, defense services, and related technical data, and further defined in the ITAR, 22 CFR Part 120.

2) "Items," defined in the EAR as "commodities", "software", and "technology," terms that are also defined in the EAR, 15 CFR 772.1.

(b) The Contractor shall comply with all applicable laws and regulations regarding export-controlled items, including, but not limited to, the requirement for contractors to register with the Department of State in accordance with the ITAR. The Contractor shall consult with the Department of State regarding any questions relating to compliance with the ITAR and shall consult with the Department of Commerce regarding any questions relating to compliance with the EAR.

(c) The Contractor's responsibility to comply with all applicable laws and regulations regarding export-controlled items exists independent of, and is not established or limited by, the information provided by this clause.

(d) Nothing in the terms of this contract adds, changes, supersedes, or waives any of the requirements of applicable Federal laws, Executive orders, and regulations, including but not limited to –

(1) The Export Administration Act of 1979, as amended (50 U.S.C. App. 2401, *et seq.*);

(2) The Arms Export Control Act (22 U.S.C. 2751, *et seq.*);

(3) The International Emergency Economic Powers Act (50 U.S.C. 1701, *et seq.*);

(4) The Export Administration Regulations (15 CFR Parts 730-774);

(5) The International Traffic in Arms Regulations (22 CFR Parts 120-130); and (6) Executive Order 13222, as extended;

(e) The Contractor shall include the substance of this clause, including this paragraph (e), in all subcontracts.

Publication Approval

As of the date of publication of this BAA, DARPA expects that program goals for this BAA may be met by proposers intending to perform 'fundamental research,' i.e., basic or applied research performed on campus in science and engineering, the results of which ordinarily are published and shared broadly within the scientific community, as

distinguished from proprietary research and from industrial development, design, production, and product utilization the results of which ordinarily are restricted for proprietary or national security reasons. Notwithstanding this statement of expectation, DARPA is not prohibited from considering and selecting research proposals that, while perhaps not qualifying as 'fundamental research' under the foregoing definition, still meet the BAA criteria for submissions. If proposals are selected for award that offer other than a fundamental research solution, then DARPA will either work with the proposer to modify the proposed statement of work to bring the research back into line with fundamental research or else the proposer will agree to restrictions in order to receive an award. See paragraphs below for further information on fundamental, non-fundamental and restricted research. In all cases, the DARPA contracting officer shall have sole discretion to select award instrument type and to negotiate all instrument provisions with selectees.

It is the policy of the Department of Defense that the publication of products of fundamental research will remain unrestricted to the maximum extent possible. The definition of Contracted Fundamental Research is:

“Contracted Fundamental Research includes [research performed under] grants and contracts that are (a) funded by budget category 6.1 (Basic Research), whether performed by universities or industry or (b) funded by budget category 6.2 (Applied Research) and performed on-campus at a university. The research shall not be considered fundamental in those rare and exceptional circumstances where the applied research effort presents a high likelihood of disclosing performance characteristics of military systems or manufacturing technologies that are unique and critical to defense, and where agreement on restrictions have been recorded in the contract or grant.” Such research is referred to by DARPA as “Restricted Research.”

Pursuant to DoD policy, research performed under grants and contracts that are (a) funded by budget category 6.2 (Applied Research) and NOT performed on-campus at a university or (b) funded by budget category 6.3 (Advanced Technology Development) does not meet the definition of fundamental research. Publication restrictions will be placed on all such research.

It is anticipated that awards for both Fundamental and Non-fundamental Research may be made as a result of this BAA. Appropriate clauses will be included in resultant awards for Non-fundamental Research to prescribe publication requirements and other restrictions, as appropriate. DARPA does not anticipate applying publication restrictions of any kind to Fundamental Research to each individual award that may result from this BAA. All Non-fundamental Research performers will be subject to pre-release review by the DARPA Public Release Center of any documents, reports, publications, press releases, web postings, blogs, tweets, and any other public release of

information generated under or pertaining to the program. Note that briefings and demos at AVM PI meetings do not constitute public release of information as they are not open fora.

For certain research projects, it may be possible that although the research being performed by the Prime Contractor is Restricted Research, a subcontractor may be conducting Contracted Fundamental Research. In those cases, it is the Prime Contractor's responsibility to explain in their proposal why its subcontractor's effort is Contracted Fundamental Research.

The following same or similar provision will be incorporated into any resultant Restricted Research or Non-Fundamental Research procurement contract or other transaction:

There shall be no dissemination or publication, except within and between the Contractor and any subcontractors, of information developed under this contract or contained in the reports to be furnished pursuant to this contract without prior written approval of DARPA's Public Release Center (DARPA/PRC). All technical reports will be given proper review by appropriate authority to determine which Distribution Statement is to be applied prior to the initial distribution of these reports by the Contractor. With regard to subcontractor proposals for Contracted Fundamental Research, papers resulting from unclassified contracted fundamental research are exempt from prepublication controls and this review requirement, pursuant to DoD Instruction 5230.27 dated October 6, 1987.

When submitting material for written approval for open publication, the Contractor/Awardee must submit a request for public release to the PRC and include the following information: 1) Document Information: document title, document author, short plain-language description of technology discussed in the material (approx. 30 words), number of pages (or minutes of video) and document type (briefing, report, abstract, article, or paper); 2) Event Information: event type (conference, principle investigator meeting, article or paper), event date, desired date for DARPA's approval; 3) DARPA Sponsor: DARPA Program Manager, DARPA office, and contract number; and 4) Contractor/Awardee's Information: POC name, e-mail and phone. Allow four weeks for processing; due dates under four weeks require a justification. Unusual electronic file formats may require additional processing time. Requests can be sent either via e-mail to prc@darpa.mil or via hard copy to 3701 North Fairfax Drive, Arlington VA 22203-1714 until April 30, 2012/675 North Randolph Street, Arlington VA 22203-2114 on or after April 30, 2012, telephone (571) 218-4235. Refer to

http://www.darpa.mil/NewsEvents/Public_Release_Center/Public_Release_Center.aspx for information about DARPA's public release process.

Security & Proprietary Issues

NOTE: If proposals are classified, the proposals must indicate the classification level of not only the proposal itself, but also the anticipated award document classification level.

The Government anticipates proposals submitted under this BAA will be unclassified. However, if a proposal is submitted as "Classified National Security Information" as defined by Executive Order 13526, then the information must be marked and protected as though classified at the appropriate classification level and then submitted to DARPA for a final classification determination. Even in cases where the open vehicleforge.mil community generates designs that may otherwise be within the scope of existing classification guidance, pursuant to DoD 5200.1-R §§ C2.3.1.1, C2.3.3, and C2.6.1 such resulting designs will be unclassified. Consequently, DARPA will work closely with all AVM performers to ensure that the scope of design crowd-sourcing is carefully tailored.

Security classification guidance via a DD Form 254, "DoD Contract Security Classification Specification," will not be provided at this time, since DARPA is soliciting ideas only. After reviewing the incoming proposals, if a determination is made that the award instrument may result in access to classified information, a DD Form 254 will be issued and attached as part of the award.

Proposers choosing to submit a classified proposal from other classified sources must first receive permission from the respective Original Classification Authority in order to use their information in replying to this BAA. Applicable classification guide(s) should also be submitted to ensure the proposal is protected at the appropriate classification level.

Classified submissions shall be appropriately and conspicuously marked with the proposed classification level and declassification date. Submissions requiring DARPA to make a final classification determination shall be marked as follows:

CLASSIFICATION DETERMINATION PENDING. Protect as though classified (insert the recommended classification level: (e.g., Top Secret, Secret or Confidential)

Classified submissions shall be in accordance with the following guidance:

Confidential and Secret Collateral Information: Use classification and marking guidance provided by previously issued security classification guides, the Information

Security Regulation (DoD 5200.1-R), and the National Industrial Security Program Operating Manual (DoD 5220.22-M) when marking and transmitting information previously classified by another Original Classification Authority. Classified information at the Confidential and Secret level may be submitted via ONE of the two following methods:

1. Hand-carried by an appropriately cleared and authorized courier to the DARPA CDR. Prior to traveling, the courier shall contact the DARPA CDR at 703-526-4052 to coordinate arrival and delivery.

OR

2. Mailed via appropriate U.S. Postal Service methods (e.g., (USPS) Registered Mail or USPS Express Mail). All classified information will be enclosed in opaque inner and outer covers and double wrapped. The inner envelope shall be sealed and plainly marked with the assigned classification and addresses of both sender and addressee.

The inner envelope shall be addressed to:

For all communications to be received prior to April 30, 2012
Defense Advanced Research Projects Agency
ATTN: TTO
Reference: BAA-12-30
3701 North Fairfax Drive
Arlington, VA 22203-1714

For all communications to be received on or after April 30, 2012
ATTN: TTO
Reference: BAA-12-30
675 North Randolph Street
Arlington, VA 22203-2114

The outer envelope shall be sealed with no identification as to the classification of its contents and addressed to:

For all communications to be received prior to April 30, 2012
Defense Advanced Research Projects Agency
Security & Intelligence Directorate, Attn: CDR
3701 North Fairfax Drive
Arlington, VA 22203-1714

For all communications to be received on or after April 30, 2012
Defense Advanced Research Projects Agency
Security & Intelligence Directorate, Attn: CDR
675 North Randolph Street
Arlington, VA 22203-2114

All Top Secret materials: Top Secret information should be hand carried by an appropriately cleared and authorized courier to the DARPA CDR. Prior to traveling, the courier shall contact the DARPA CDR at 703-526-4052 to coordinate arrival and delivery.

Special Access Program (SAP) Information: SAP information must be transmitted via approved methods. Prior to transmitting SAP information, contact the DARPA SAPCO at 703-526-4052 for instructions.

Sensitive Compartmented Information (SCI): SCI must be transmitted via approved methods. Prior to transmitting SCI, contact the DARPA Special Security Office (SSO) at 703-526-4052 for instructions.

Proprietary Data: All proposals containing proprietary data should have the cover page and each page containing proprietary data clearly marked as containing proprietary data. It is the Proposer's responsibility to clearly define to the Government what is considered proprietary data.

Proposers must have existing and in-place prior to execution of an award, approved capabilities (personnel and facilities) to perform research and development at the classification level they propose. It is the policy of DARPA to treat all proposals as competitive information, and to disclose their contents only for the purpose of evaluation. Proposals will not be returned. The original of each proposal received will be retained at DARPA and all other non-required copies destroyed. A certification of destruction may be requested, provided the formal request is received at this office within 5 days after unsuccessful notification.

III. PROPOSAL REQUIREMENTS

Proposals shall be submitted as a single volume following the section structure outlined below. Proposals must be on 8.5 inch x 11 inch plain white paper, in 12 point font, and with 1 inch margins. Smaller font may be used for figures, tables and charts. The inclusion of 11 inch x 17 inch fold-outs for large figures is permitted. Proposals must be in English.

There is no page limit on the length of proposals. However, conciseness and clarity of prose is strongly encouraged. Except in the statement of work and cost proposal which must comport to a certain standard of detail as described below, proposers are encouraged to be succinct. Proposers should, however, be as definitive as possible in their characterization of the proposed effort, providing quantitative characterizations where appropriate, and concretely identifying approaches, tools, equipment, etc. to be employed.

1. Cover Page

The cover page should include the BAA number (DARPA-BAA-12-30), the name of the proposing organization which would receive the contract (prime performer organization); indicate whether the prime performer is categorized as "large business," "small disadvantaged business," "other small business," "historically black college or university (HBCU)," "minority institution (MI)," "other educational," or "nonprofit"; the names of ALL subcontractor or team member organizations and their categorization; the title of the proposal; a technical and an administrative point of contact for the proposal (which can be the same person) and their title, mailing address, telephone, and e-mail; total proposed cost for the base and each option period; proposal validity period (minimum 120 days); affirmation that the proposing organization and individual team members are not providing scientific, engineering, and technical assistance (SETA) or similar support to any DARPA technical office(s) through an active contract or subcontract; affirmation that there is no animal or human use research in the proposed effort.

2. Technical Approach

This section should provide a detailed description of the proposed technical approach to the problem outlined in this BAA. Proposers should provide an overview of the overarching philosophy, as well as approach to integration across the various tasks in subsection 2.0. For each technical area being proposed to, the proposer will provide an overview of their approach in subsections 2.1 through 2.3 (as needed). This section will serve as the primary expression of the proposer's scientific and technical ideas. It should also include the proposer's understanding of the state of

the art approaches and the limitations that relate to each topic addressed by the proposal. Describe and analyze state of the art results, approaches, and limitations within the context of the problem area addressed by this research. Demonstrating problem understanding requires not just the enumeration of related efforts; rather, related work must be compared and contrasted to the proposed approach. Conciseness is strongly encouraged.

3. Intellectual Property Approach

This section of the proposal should detail the proposer’s intellectual property approach. As described in this BAA, DARPA desires Unlimited Rights to all deliverables generated by performers under this effort except clearly-identified, widely-available, commercial software tools, with their commercial availability described and substantiated in the proposal. Proposers must document in this section any data or software that will be delivered with less than Unlimited Rights, including commercial data or software, in the following format as prescribed by DFARS 252.227-7013, Rights in Technical Data--Noncommercial Items, DFARS 252.227-7014, Rights in Noncommercial Computer Software and Noncommercial Computer Software Documentation, and DFARS 252.227-7015, Technical Data--Commercial Items:

Technical Data or Computer Software to Be Furnished with Restrictions or That Is Commercial	Summary of Intended Use in the Course of Performance	Basis for Assertion	Asserted Rights Category	Name of Person Asserting Restrictions
(LIST)	(NARRATIVE)	(LIST)	(LIST)	(LIST)

Finally, proposers must provide a good-faith representation that they either own or possess appropriate licensing rights to all other intellectual property that will be utilized in the course of performance of the proposed effort.

4. Management Approach

This section should describe the proposer’s team and how it will be managed in the course of performance. An organizational chart should be included, noting any relationships with subcontractors, independent consultants, major vendors, and any other external parties on whom the

proposer will rely in the course of performance.¹³ The nature of the relationship should be described in some detail, including any legal instruments (contracts, purchase orders, teaming agreements, etc.), their status as of the time of the proposal (envisioned, pending negotiation, in place, etc.), and key provisions that substantively affect the allocation of cost, schedule, and performance risk between the proposer and the counterparty. Any other notable attributes or aspects of the proposer’s management approach should be described in this section. Letters of commitment and any other relevant documentation may be included as appendices to this section.

5. Key Personnel

This section should identify by name the key personnel that the proposer is committing to use if selected for award. Note that these personnel will be identified by name in the resultant contract and DARPA will monitor their level of effort in the course of performance based on monthly personnel hours reports described in the BAA section on deliverables. Proposers should not propose personnel whom they do not intend to employ on the contract. This section should include brief biographies, including education and work history, of key personnel and especially describe the individual’s experience and past performance on efforts that are relevant to their qualification for C2M2L-2. Additionally, proposers should supply a table indicating the level of effort in terms of hours to be expended by each key person during each calendar year of the effort and other (current and proposed) major sources of support for them and/or commitments of their efforts. DARPA expects all key personnel associated with a proposal to make substantial time commitment to the proposed activity and the proposal will be evaluated accordingly.

Include a table of key individual time commitments as follows:

Individual	Project	Pending/Current	CY 2012	CY 201X
Jane Doe	C2M2L-2	Proposed	Y hours	Z hours
	Project A	Current	Y hours	Z hours
	Project B	Pending	Y hours	Z hours
John Deer	C2M2L-2	Proposed	Y hours	Z hours

6. Schedule & Major Milestones

This section should depict an integrated master schedule for the proposed effort depicting major milestones, deliverables, and dependencies between

¹³ Do not forget that an exhaustive list of all subcontractors, consultants, and major vendors must also be supplied on the cover page of the proposal.

tasks. A critical schedule path should be depicted and tasks/events on the critical schedule path should be identified and described. The schedule should be relative to the date of contract award. Measurable milestones should capture key development points in tasks and should be clearly articulated and defined in time relative to start of effort.

7. Statement of Work (SOW) to Be Performed

The SOW should include a list of tasks that the awardee will accomplish in the course of contract performance if awarded under this solicitation. Major task categories should correlate to the tasks listed in the BAA, but additional tasks may (and should) be included and the overall organization scheme for the SOW is at the discretion of the proposer. The tasks should be discrete activities with clear delineation of scope, responsibility, schedule, and outcome. (Note: Measurable milestones should capture key development points in tasks and should be clearly articulated and defined in time relative to start of effort.) Each task should be described with an imperative statement (“The performer shall do X, Y, Z...”), followed by an elaboration of the scope of the task, who will perform the task (responsible organization and individuals), when it will be commenced and concluded, and what the concrete outcome or deliverable of the task will be. There is no limit on the length of the SOW, but 2-3 pages of single-spaced narrative per \$1 million in proposed cost is offered as an advisory guideline. The SOW must begin and end on a new page and each page of the SOW must not contain any restrictive markings such as Proprietary, Competition Sensitive, etc. as the SOW will be incorporated in the award instrument if the proposal is selected.

8. Cost

This section should delineate the proposed costs by task as listed in the SOW. For each task, the cost should be broken out by major cost category (direct labor; materials; travel; other direct costs, overhead charges, etc.) and a basis of estimate and rationale should be supplied for each task and cost category. Labor categories and hourly personnel costs must be identified. Note that this information must be supplied for all team members, including any subcontractors, consultants, etc. Bills of materials and vendor price quotes must be included to substantiate any purchases of materials, equipment, or other direct costs. For major expenditures, evidence of competitive vendor selection should be included. A cost summary by team member and major vendor should be included. Overall cost should also be broken down by month relative to the award date (i.e.,

award+1 month, +2 months, etc.).¹⁴ The source, nature, and amount of any cost-sharing should be separately documented. Any profit or fee should be explicitly detailed and justified. Finally, on the last page of the cost proposal, the proposer should provide, where known, the name and contact information for their cognizant Defense Contract Management Agency (DCMA) and Defense Contract Audit Agency (DCAA) officials, the proposer's official business address, the address(es) where performance will take place, commercial and government entity (CAGE) code, taxpayer identification number (TIN), and DUNS number.

Proposers should submit two (2) hard copies of their proposal and two (2) CD-ROMs containing the entire proposal as a single Adobe PDF file to the following address(es):

For proposals to be received prior to April 30, 2012
DARPA/TTO
Attn: LTC Nathan Wiedenman, DARPA-BAA-12-30
3701 North Fairfax Drive
Arlington, VA 22203-1714

For proposals to be received on or after April 30, 2012
DARPA/TTO
Attn: LTC Nathan Wiedenman, DARPA-BAA-12-30
675 North Randolph Street
Arlington, VA 22203-2114

No e-mailed or faxed proposals will be accepted. The initial deadline for proposal submissions is 1400 (2:00pm) Eastern Time on April 24, 2012. The closing date for this BAA is 1400 (2:00pm) Eastern Time on August 24, 2012. The dates and times indicated are deadlines by which proposals must be received by DARPA.

Proposers are required to submit proposals by the time and date specified in the BAA in order to be considered during the initial round of selections. DARPA may evaluate proposals received after this date for a period up to one year from date of posting on FedBizOpps and Grants.gov. Ability to review late submissions remains contingent on availability of funds.

¹⁴ To summarize and restate, three separate cost views should be included in the cost proposal. Costs should be broken down: (1) by each SOW task and cost category; (2) by team member including subcontractors, consultants, and vendors; and (3) by month of performance with sums for the base period and each option period. The first view must be substantiated with bases of estimate and vendor quotes for each task and cost category.

IV. PROPOSAL EVALUATION CRITERIA

Evaluation of proposals will be accomplished through a scientific/technical review of each proposal. Proposals will not be evaluated against each other since they are not submitted in accordance with a common statement of work (SOW). DARPA's intent is to review proposals as soon as possible after they arrive; however, proposals may be reviewed periodically for administrative reasons. Proposals will be evaluated using the following criteria, listed in descending order of importance:

1. Overall Scientific and Technical Merit:

The proposed technical approach is innovative, feasible, achievable, complete and supported by a proposed technical team that has the expertise and experience to accomplish the proposed tasks. The soundness and innovativeness of proposed technical approach, the flexibility of proposed approach to accommodate technical uncertainty, and the likelihood of technical success of proposed technical approach will be evaluated. The expertise and experience of the proposer's proposed technical team will be evaluated based upon the qualifications of the key personnel proposed for the effort and their previous accomplishments on similar efforts.

2. Potential Contribution and Relevance to the DARPA Mission:

The potential contributions of the proposed effort with relevance to the national technology base will be evaluated. Specifically, DARPA's mission is to maintain the technological superiority of the U.S. military and prevent technological surprise from harming our national security by sponsoring revolutionary, high-payoff research that bridges the gap between fundamental discoveries and their application. The proposal will also be evaluated based on a demonstrated understanding of DARPA's goals for the C2M2L program and the likelihood of successful integration of proposed effort into the overarching Adaptive Vehicle Make portfolio.

3. Potential to Accomplish Technology Transition:

The proposal will be evaluated on the extent to which proposed intellectual property approach will support open source promulgation and other avenues of technology transition for selected deliverables.

4. Cost Realism

The objective of this criterion is to establish that the proposed costs are realistic for the technical and management approach offered, as well as to determine the proposer's practical understanding of the effort. The proposal will be reviewed to determine if the costs proposed are based on realistic assumptions, reflect a sufficient understanding of the technical goals and objectives of the BAA, and are consistent with the proposer's technical approach (to include the proposed SOW). At a minimum, this will involve review, at the prime and subcontract level, of the type and number of labor hours

proposed per task as well as the types and kinds of materials, equipment and fabrication costs proposed.

Award will be made to the proposer whose proposal is determined to be the most advantageous to the government, all factors considered, including the potential contributions of the proposed work to the overall research program and the availability of funding for the effort.

It is the policy of DARPA to ensure impartial, equitable, comprehensive proposal evaluations and to select the source (or sources) whose offer meets the government's technical, policy, and programmatic goals. Pursuant to FAR 35.016, the primary basis for selecting proposals for acceptance shall be technical, importance to agency programs, and funds availability. In order to provide the desired evaluation, qualified government personnel will conduct reviews and (if necessary) convene panels of experts in the appropriate areas.

Restrictive notices notwithstanding, proposals may be handled for administrative purposes by support contractors. These support contractors are prohibited from competition in DARPA technical research and are bound by appropriate non-disclosure requirements.

Subject to the restrictions set forth in FAR § 37.203(d), input on technical aspects of the proposals may be solicited by DARPA from non-government consultants/experts who are strictly bound by appropriate conflict of interest and non-disclosure requirements.

It is the policy of DARPA to treat all proposals as competitive information and to disclose their contents only for the purpose of evaluation. No proposals will be returned. After proposals have been evaluated and selections made, electronic copies of each proposal received will be retained at DARPA and all other copies will be destroyed.

V. ELIGIBILITY INFORMATION & ADDITIONAL REQUIREMENTS

Eligibility & Conflicts of Interest

There are no restrictions on C2M2L-2 proposers contacting or teaming with existing performers on the META, iFAB, *vehicleforge.mil*, FANG, or other AVM portfolio efforts.

Without prior approval or a waiver from the DARPA Director, in accordance with FAR 9.503, an awardee cannot simultaneously provide scientific, engineering, technical assistance (SETA) or similar support and also be a technical performer. Therefore, all proposers as well as proposed subcontractors and consultants must affirm whether they (their organizations and individual team members) are providing SETA or similar support to any DARPA technical office(s) through an active contract or subcontract. All affirmations must state which office(s) the proposer, subcontractor, consultant, or individual supports and identify the prime contract number(s). Affirmations shall be furnished at the time of proposal submission. All facts relevant to the existence or potential existence of organizational conflicts of interest (FAR 9.5) must be disclosed. The disclosure must include a description of the action the proposer has taken or proposes to take to avoid, neutralize, or mitigate such conflict. If in the sole opinion of the government after full consideration of the circumstances, a proposal fails to fully disclose potential conflicts of interest and/or any identified conflict situation cannot be effectively mitigated, the proposal will be rejected without technical evaluation and withdrawn from further consideration for award.

If a prospective proposer believes that any conflict of interest exists or may exist (whether organizational or otherwise) or has questions on what constitutes a conflict of interest, the proposer should promptly raise the issue with DARPA by sending his/her contact information and a summary of the potential conflict to the DARPA-BAA-12-30@darpa.mil mailbox before time and effort are expended in preparing a proposal and mitigation plan.

All responsible sources capable of satisfying the Government's needs may submit a proposal that shall be considered by DARPA. Historically Black Colleges and Universities (HBCUs), Small Businesses, Small Disadvantaged Businesses and Minority Institutions (MIs) are encouraged to submit proposals and join others in submitting proposals; however, no portion of this announcement will be set aside for these organizations' participation due to the impracticality of reserving discrete or severable areas of this research for exclusive competition among these entities.

Federally Funded Research and Development Centers (FFRDCs) and government entities (government/national laboratories, military educational institutions, etc.) are subject to applicable direct competition limitations and cannot propose to this solicitation in any capacity unless they address the following conditions. FFRDCs must

clearly demonstrate that the proposed work is not otherwise available from the private sector AND must also provide a letter on letterhead from their sponsoring organization citing the specific authority establishing their eligibility to propose to government solicitations and compete with industry, and compliance with the associated FFRDC sponsor agreement and terms and conditions. This information is required for FFRDCs proposing to be prime or subcontractors. Government entities must clearly demonstrate that the work is not otherwise available from the private sector and provide written documentation citing the specific statutory authority (as well as, where relevant, contractual authority) establishing their ability to propose to government solicitations. At the present time, DARPA does not consider 15 USC § 3710a to be sufficient legal authority to show eligibility. While 10 USC § 2539b may be the appropriate statutory starting point for some entities, specific supporting regulatory guidance, together with evidence of agency approval, will still be required to fully establish eligibility. DARPA will consider eligibility submissions on a case-by-case basis; however, the burden to prove eligibility for all team members rests solely with the proposer.

Current federal employees are prohibited from participating in particular matters involving conflicting financial, employment, and representational interests (18 USC §§ 203, 205, and 208). The DARPA Program Manager for this solicitation is Paul Eremenko and Deputy Program Manager is LTC Nathan Wiedenman. Once the proposals have been received, and prior to the start of proposal evaluations, the government will assess potential conflicts of interest and will promptly notify the proposer if any appear to exist. (Please note, the government assessment does NOT affect, offset, or mitigate the proposer's own duty to give full notice and planned mitigation for all potential organizational conflicts, as discussed above.)

Animal & Human Use

All research involving human subjects, to include use of human biological specimens and human data, selected for funding must comply with the federal regulations for human subject protection. Further, research involving human subjects that is conducted or supported by the DoD must comply with 32 CFR 219, *Protection of Human Subjects* (http://www.access.gpo.gov/nara/cfr/waisidx_07/32cfr219_07.html) and DoD Directive 3216.02, *Protection of Human Subjects and Adherence to Ethical Standards in DoD-Supported Research* (<http://www.dtic.mil/whs/directives/corres/pdf/321602p.pdf>).

Institutions awarded funding for research involving human subjects must provide documentation of a current Assurance of Compliance with Federal regulations for human subject protection, for example a Department of Health and Human Services, Office of Human Research Protection Federal Wide Assurance (<http://www.hhs.gov/ohrp>). All institutions engaged in human subject research, to include subcontractors, must also have a valid Assurance. In addition, personnel

involved in human subjects research must provide documentation of completing appropriate training for the protection of human subjects.

For all proposed research that will involve human subjects in the first year or phase of the project, the institution must provide evidence of or a plan for review by an Institutional Review Board (IRB) upon final proposal submission to DARPA. The IRB conducting the review must be the IRB identified on the institution's Assurance. The protocol, separate from the proposal, must include a detailed description of the research plan, study population, risks and benefits of study participation, recruitment and consent process, data collection, and data analysis. Consult the designated IRB for guidance on writing the protocol. The informed consent document must comply with federal regulations (32 CFR 219.116). A valid Assurance along with evidence of appropriate training all investigators should all accompany the protocol for review by the IRB.

In addition to a local IRB approval, a headquarters-level human subjects regulatory review and approval is required for all research conducted or supported by the DoD. The Army, Navy, or Air Force office responsible for managing the award can provide guidance and information about their component's headquarters-level review process. Note that confirmation of a current Assurance and appropriate human subjects protection training is required before headquarters-level approval can be issued.

The amount of time required to complete the IRB review/approval process may vary depending on the complexity of the research and/or the level of risk to study participants. Ample time should be allotted to complete the approval process. The IRB approval process can last between one to three months, followed by a DoD review that could last between three to six months. No DoD/DARPA funding can be used towards human subjects research until ALL approvals are granted.

Any Recipient performing research, experimentation, or testing involving the use of animals shall comply with the rules on animal acquisition, transport, care, handling, and use in: (i) 9 CFR parts 1-4, Department of Agriculture rules that implement the Laboratory Animal Welfare Act of 1966, as amended, (7 U.S.C. 2131-2159); (ii) the guidelines described in National Institutes of Health Publication No. 86-23, "Guide for the Care and Use of Laboratory Animals"; (iii) DoD Directive 3216.01, "Use of Laboratory Animals in DoD Program."

For submissions containing animal use, proposals should briefly describe plans for Institutional Animal Care and Use Committee (IACUC) review and approval. Animal studies in the program will be expected to comply with the PHS Policy on Humane Care and Use of Laboratory Animals, available at <http://grants.nih.gov/grants/olaw/olaw.htm>.

All Recipients must receive approval by a DoD certified veterinarian, in addition to an IACUC approval. No animal studies may be conducted using DoD/DARPA funding until the USAMRMC Animal Care and Use Review Office (ACURO) or other appropriate DoD veterinary office(s) grant approval. As a part of this secondary review process, the Recipient will be required to complete and submit an ACURO Animal Use Appendix, which may be found at https://mrmc-www.army.mil/index.cfm?pageid=Research_Protections.acuro&rn=1.

If a potential proposer envisions the need for human or animal use, the proposer should promptly raise the issue with DARPA by sending his/her contact information and a summary of the potential human or animal use to the DARPA-BAA-12-30@darpa.mil mailbox for further instructions. Failure to notify DARPA of planned human or animal use prior to submission of a proposal may result in the proposal being disqualified from review.

Miscellaneous Statutory Requirements

Unless the proposer is exempt from this requirement, as per FAR 4.1102 or 2 CFR § 25.110 as applicable, all proposers must be registered in the Central Contractor Registration (CCR) and have a valid Data Universal Numbering System (DUNS) number prior to submitting a proposal. Information on CCR registration is available at <http://www.ccr.gov>. All proposers must maintain an active CCR registration with current information at all times during which they have an active federal award or proposal under consideration by DARPA. All proposers must provide the DUNS number in each proposal they submit. DARPA cannot make an assistance award to an proposer until the proposer has provided a valid DUNS number and has maintained an active CCR registration with current information.

As per FAR 22.1802, recipients of FAR-based procurement contracts must enroll as Federal Contractors in E-verify and use E-Verify to verify employment eligibility of all employees assigned to the award. All resultant contracts from this solicitation will include FAR 52.222-54, Employment Eligibility Verification. This clause will not be included in cooperative agreements or Other Transactions.

The FAR clause 52.204-10, "Reporting Executive Compensation and First-Tier Subcontract Awards," will be used in all procurement contracts valued at \$25,000 or more. A similar award term will be used in all cooperative agreements.

FAR 52.209-9, Updates of Publicly Available Information Regarding Responsibility Matter, will be included in all contracts valued at \$500,000 where the contractor has current active Federal contracts and grants with total value greater than \$10,000,000.

In accordance with FAR 4.1201, proposers will be required to complete electronic annual representations and certifications at <http://orca.bpn.gov> prior to contract award.

In accordance with sections 8124 and 8125 of Division A of the Consolidated Appropriations Act, 2012 (Pub. L. 112-74) none of the funds made available by that Act may be used to enter into a contract with any corporation that –

- Has any unpaid Federal tax liability that has been assessed, for which all judicial and administrative remedies have been exhausted or have lapsed, and that is not being paid in a timely manner pursuant to an agreement with the authority responsible for collecting the tax liability, unless the agency has considered suspension or debarment of the corporation and made a determination that this further action is not necessary to protect the interests of the Government.
- Was convicted of a felony criminal violation under any Federal law within the preceding 24 months, where the awarding agency is aware of the conviction, unless the agency has considered suspension or debarment of the corporation and made a determination that this action is not necessary to protect the interests of the Government.

Each proposer must complete and return the following representations with their proposal submission: The Proposer represents that –

- It is is not a corporation that has any unpaid Federal tax liability that has been assessed, for which all judicial and administrative remedies have been exhausted or have lapsed, and that is not being paid in a timely manner pursuant to an agreement with the authority responsible for collecting the tax liability,
- It is is not a corporation that was convicted of a felony criminal violated under Federal law within the preceding 24 months.

As per FAR 52.230-2, amended by Deviation 2012-00003 (JAN 2012), any procurement contract in excess of \$700,000 resulting from this solicitation will be subject to the requirements of the Cost Accounting Standards Board (48 CFR Chapter 99), except those contracts which are exempt as specified in 48 CFR 9903.201-1. Any offeror submitting a proposal which, if accepted, will result in a cost accounting standards (CAS) compliant contract, must submit representations and a Disclosure Statement as required by 48 CFR 9903.202 detailed in FAR 52.230-2.

APPENDIX 1: PHILOSOPHICAL UNDERPINNINGS OF ADAPTIVE VEHICLE MAKE

Introduction

At DARPA, we say that *to innovate, we must make* and *to protect, we must produce*. These words ring true to most private-sector entrepreneurs, but they are increasingly anathema to the way we do business in defense. Historical as well as present-day examples of disruptive innovations--from Pasteur, to Kalashnikov, to Kilby--are almost invariably predicated on discoveries and refinements made in the course of manufacture. And while the epicenter of battle may be increasingly shifting into the digital domain, the defense of flesh, blood, and territory is still the culmination of modern warfare. Tanks, airplanes, ships, and satellites--systems made of atoms as well as bits--are in no danger of disappearing from the battlefield in the foreseeable future. Increasingly, however, such next generation systems are born, live, and die as little more than figments of PowerPoint. To put it another way, *vision without execution is day-dreaming*. And day-dreaming is of little use to the warfighter.

Norm Augustine, in his "Final Law of Economic Disarmament," plots aircraft unit costs versus time since the advent of aviation.¹⁵ Upon projection into the future, the lamentable trend suggests that by the year 2054 the entire U.S. defense budget will purchase just one aircraft.¹⁶ And while we must remain wary of falling into the Malthusian fallacy of extrapolating exponentials into the indefinite future, the fact remains that program after program we have hewed close to the trend line. The number of major system new starts across every domain of military systems has dwindled to fewer than one per decade,¹⁷ and correspondingly, the number of major system manufacturers barely scrapes by for an oligopoly. If the imperatives in the first sentence of this paper hold true, then we are in trouble.

Augustine's law is correlative, but tells us little about causality. The single biggest driver behind increased aircraft costs has been schedule growth, and the principal cause of schedule growth is increasing product complexity.¹⁸ This causal chain runs in the

¹⁵ N.R. Augustine, *Augustine's Laws*, American Institute of Aeronautics & Astronautics, Reston, VA, 6th ed., 1997, pp. 104-110.

¹⁶ As Augustine, *ibid.*, and others point out, the same trend with slightly different exponentials holds true in other system domains such as ships, satellites, and military ground vehicles. See, e.g., M.V. Arena, I. Blickstein, et al., *Why Has the Cost of Navy Ships Risen?*, Report No. MG-484, RAND Corporation, Santa Monica, CA, 2006.

¹⁷ For aircraft, see, e.g., P.S. Antón, E.C. Gritton, et al., *Wind Tunnel and Propulsion Test Facilities*, Report No. MG-178, RAND Corporation, Santa Monica, CA, 2004, pp. 14-15.

¹⁸ A recent RAND report attributes approximately half of the escalation in fighter aircraft costs between 1975 and 2005 to schedule growth associated with increased complexity. M.V. Arena, O. Younossi, et al.,

face of much conventional wisdom--that the bureaucracy is getting increasingly dysfunctional, that the acquisition system is becoming more and more byzantine, and that the talents of the program management cadre are atrophying. We do not dispute the actuality or acuity of any of these phenomena. DARPA, however, is a technology organization and the roots of this problem are fundamentally technological. There is also a long history of disruptive technological solutions precipitating rapid policy reform.

Military aerospace systems have sustained approximately a three to four order of magnitude increase in complexity over the past half-century. Commensurately, their development timelines grew from an average of 36 to 48 months, to 12-15 years today. The projection for next-generation systems is one to two additional orders of magnitude in complexity growth, with development timelines potentially reaching two decades. And while some of the increased complexity is undoubtedly gratuitous (an artifact of inefficient design), most of it is driven by a drive toward increased connectivity, efficiency, safety, and performance (probably in that order).

The phenomenology of complex systems is characterized--across systems in every domain: biological, financial, computational, and engineered alike--by unanticipated interactions, emergent behaviors, and occasional catastrophic cascading failures. In engineered systems, the discipline of systems engineering was devised with the express goal of decomposing the system into humanly-tractable design problems, and managing the interactions throughout the system as the individually-designed pieces are integrated.

Systems engineering was originally developed by Simon Ramo of the Ramo-Woolridge Corporation (subsequently TRW), under the tutelage of Gen. Bernard Schriever, in the course of designing and building the Atlas ICBM.¹⁹ The systems engineering approach was vigorously applied and refined in the course of Apollo. It was subsequently codified in 1969 as MIL-STD-499A. Remarkably, the methodology is largely unchanged today. With the exception of tools that expedite certain steps in the process, the process as a whole is very much as it was a half-century prior.

A stylized depiction of the systems engineering process is the so-called "V." The downward portion of the V corresponds to the decomposition of the system along functional groups, and the flow-down and allocation of requirements as the system is decomposed. The cleavage lines for this decomposition process are disciplinary stovepipes--there is nothing fundamental or optimal about the breakdown of the system except that the functional stovepipes correspond to the manner in which we train

Why Has the Cost of Fixed-Wing Aircraft Risen?, Report. No. MG-696, RAND Corporation, Santa Monica, CA, 2008, p. xvii.

¹⁹ T.P. Hughes, *Rescuing Prometheus*, Pantheon Books, New York, NY, 1998, pp. 69-139.

engineers. Once the system is decomposed to the component level, requirements are allocated, and components are optimally designed to meet these requirements.

The upward-sloping portion of the V is the subsequent composition--or integration--process. Components are assembled, integrated, and tested. Inevitably, unanticipated interactions emerge in the course of integration. It is the systems engineer's principal occupation at this point in the process to "chase" and try to anticipate these interactions before they manifest themselves in the laboratory or on the factory floor. She is destined to fail, however, since the number of interactions scales exponentially with the number of components; cyber-physical interactions add a layer of complexity beyond that. And so, inevitably, a re-design cycle begins. In fact, the two sides of the V are ever more interconnected with increasingly frequent re-designs. This re-design in the course of integration is the principal cause of schedule growth in modern complex military systems.²⁰ The problem of complexity is more insidious than that, however. The number of possible states and configurations of a modern aircraft, for instance, vastly exceeds our ability to test them exhaustively. The test timeline is increasingly itself a major driver of development schedules. Yet today's systems engineering lore is replete with stories of discovering fundamental design flaws in the newest fighter jet its first time on the runway.

Why hasn't the systems engineering approach been reinvented to better cope with increasing product complexity? The answer probably lies in a peculiar trait of the defense industry: it is the only industry in which the product is bought before it is ever made. In virtually every other industry the seller makes the product before the consumer buys it. The seller therefore has a strong incentive to control for time in the development process; in defense, he does not.²¹

Existence Proof

Aerospace and defense systems are not unique in their inexorable complexity growth. In fact, technological progress is almost ubiquitously exponential.²² One industry in particular, however, stands out for its ability to sustain a dramatic increase in product complexity while maintaining development timelines completely constant. That industry is integrated circuits.

Moore's Law is a double-edged sword. The good news is that the number of transistors on a chip doubles every 18 months. The bad news, however, is that the number of

²⁰ M. Giffin, O. de Weck, et al., "Change Propagation Analysis in Complex Technical Systems," *Journal of Mechanical Design*, Vol. 131, No. 8, Aug. 2009, p. 13.

²¹ The perverse incentives of cost-plus contracting and the removal of competitive schedule pressure by rigid acquisition plans surely have something to do with it also.

²² See, e.g., R. Kurzweil, *The Singularity Is Near*, Viking, 2005 which eloquently describes a myriad of exponential trends in a variety of technology domains.

transistors on a chip *doubles* every 18 months. In other words, product complexity increases rapidly, even as does capability. By the early 1980s, the progenitor and behemoth of the integrated circuit industry was at a critical juncture. On the one hand, Intel's hugely successful "tick-tock" product development strategy set the cadence for the entire computer industry--the market expected a new processor every 24 months.²³ On the other hand, Intel was facing challenges with the development of the 80386 processor. The manual approach to chip design which had been employed since the company's inception relied on designer know-how to do the circuit layout, route the data and power paths, and build and test numerous prototypes at the company's in-house fabrication facilities. The approach was not scaling well to cope with the nearly 300,000 transistors in the 80386. Intel turned to a University of California at Berkeley spin-off called Cadence Design Systems to productize in a set of design tools a fundamentally novel design approach developed by Carver Mead and Lynn Conway in the late 1970s.²⁴ The approach, called Very Large Systems Integration (VLSI), was predicated on several pivotal insights:

- Raising the level of abstraction on the design process. Enabling the designer to express her functional intent for the product, rather than having to manipulate the design at the transistor or even the logic gate level.
- Giving up component-level optimality in exchange for system-level verifiability and shortened development times. Performance is easily bought back through frequent technology insertion and product refreshes.
- Verifying the design virtually using detailed models, such that it is correct-by-construction. In other words, the very first chip out of the fab is assured to work almost every time.

The proliferation of VLSI design and associated electronic design automation (EDA) tools has enabled the integrated circuit industry to sustain almost four orders of magnitude in product complexity growth since the 80386 to the present day, while maintaining a consistent product development timeline. It also had an interesting effect on industrial structure. The advent of correct-by-construction design, afforded by investment in little more than a software tool suite, eliminated the need for a captive fabrication facility to support design iteration in the course of new product development. By eliminating the barrier-to-entry associated with the capital requirements of owning and operating a fab, it enabled the separation of design from manufacturing and led to the inception of thousands upon thousands of "fab-less" design firms, along with a consolidation and commoditization of manufacturing in large "silicon foundries." The foundries were (and are) programmable fabrication

²³ S.R. Shenoy & A. Daniel, *Intel Architecture and Silicon Cadence: The Catalyst for Industry Innovation*, Intel Corp. White Paper, 2006, available at <http://tinyurl.com/ticktockpaper> (last visited 12 Oct. 2011).

²⁴ C. Mead & L. Conway, *Introduction to VLSI Systems*, Addison-Wesley, 1980.

facilities that could rapidly switch from one design to another, enabling efficient production in quantities of one or quantities of millions. The flip side of the foundry construct was that designers had to make their design conform to the fabrication capabilities of the foundry. This was accomplished through a set of formal design rules that could be used to appropriately constrain the design up front.

To many, it seems preposterous to claim that an integrated circuit provides a useful archetype for the design of an aircraft or ground vehicle. To be sure, there are differences. An integrated circuit consists of fairly homogeneous components--nearly identical gates, transistors, and blocks. It is weakly coupled to the environment, such that an assumption of synchrony can be made. Neither of these is true for an aircraft or ground vehicle. On the other hand, in spite of its diminutive size in contrast to, say, an armored vehicle, an integrated circuit has many more interacting components, analogous cyber-physical interaction challenges, and a comparable number of physics domains that must be modeled in the design process. In other words, VLSI design does not solve the design problem for defense systems, but it does provide an instructive template.

A superficially-analogous disaggregation of the value chain in defense manufacturing can be observed among most of the principal aerospace and defense prime contractors in their divestiture of tier-one and lower manufacturing capability. It has, however, been accompanied by neither a comparable increase in innovation, nor exponential growth in product capability, nor decrease in product development timelines. On the contrary, the defense industry has worsened in its performance in each of these areas, arguably because it has never put in place the technological enablers of a truly disaggregated value chain, thereby confining many major defense and aerospace firms to the “purgatory” between the two models.

Portfolio

In 2009, DARPA embarked on a roadmap of investments in manufacturing, totaling an estimated \$1 billion over five years.²⁵ In domain after domain, we saw escalating timelines for making products essential to the warfighter, constraining our ability to adapt to the rapidly changing threat environment and adversarial countermeasures. We firmly believe that *controlling for time* is the quintessence of adaptability, enabling adaptation to new geopolitical realities, facilitating the rapid insertion of new technologies, and invigorating innovation. To that end, we have set the goal of dramatically shortening product development timelines in a variety of product domains by applying the same template for managing complexity--raising the level of abstraction in the design process, consciously giving up component-level optimality in

²⁵ R.E. Dugan, *Statement by Director, Defense Advanced Research Projects Agency to the Subcommittee on Emerging Threats and Capabilities, United States House of Representatives*, 1 Mar. 2011, p. 13, available at <http://www.darpa.mil/WorkArea/DownloadAsset.aspx?id=2929> (last visited 17 Oct. 2011).

exchange for ease of verification, decoupling design and fabrication, and utilizing foundry-style manufacturing. We have applied this paradigm to the making of pharmaceuticals and vaccines, to synthetic biology, to optics, to sensors, and to vehicles.

Making Military Vehicles

With the AVM programs, we seek to mirror the VLSI revolution for the much more heterogeneous class of cyber-electro-mechanical systems that represent the overwhelming majority of Department of Defense (DoD) acquisitions.²⁶ As a proof of principle and the first controlled experiment at scale, DARPA has partnered with the Marine Corps with an effort to parallel the Amphibious Combat Vehicle (ACV) program of record and produce a heavy, amphibious infantry fighting vehicle called FANG²⁷ to identical requirements with at least a factor of five compression in the development timeline.

A partial “existence proof” that this goal might be attainable can be found in the experience of one particular aircraft maker. This firm represents perhaps the most faithful adopter of the high-end computer-aided design and manufacturing (CAD/CAM) and product lifecycle management (PLM) tool suites. They have fully embraced the digital master model of its airplanes’ geometry as the principal artifact driving design, manufacturing, and product lifecycle sustainment. The digital master model is unique to each aircraft, tagged by tail number, and constantly updated with actual quality assurance/quality control (QA/QC) once a part is manufactured. The digital model is continuously updated to ensure that the design remains geometrically correct, thereby enabling a virtually shim-less production process. The company’s production floor resembles a showroom more than a conventional airplane factory; there is no shimming, no drill-and-fill, and an arms-length relationship with the supply chain for structural components—enforced by strict adherence to the digital model. The aircraft maker claims up to a two-fold reduction in development timelines for the latest generation of airplanes through this strict adherence to the geometric digital master model and the resultant savings in re-design and bespoke manufacturing consequent to a correct-by-construction geometric design. What if this approach could be extended to physics domains and properties other than static structural geometry of a system? This is precisely what the META program aims to do.

The META program is developing an approach for formal semantic integration across existing domain-specific modeling languages to encapsulate the totality of static and dynamic models needed to represent complex cyber-electro-mechanical systems; a set of design tools and metrics for performing design trade-space exploration; and a set of

²⁶ We use the term “cyber-electro-mechanical system” to refer to any system that incorporates mechanical, electrical/electronic, and embedded software components. Examples include aircraft, satellites, ships, and ground vehicles.

²⁷ Fast, Adaptable Next-Generation Ground Vehicle (FANG)

verification tools for stochastic formal verification of large, highly-heterogeneous system designs. The META capability, once complete, promises to:

- Raise the level of abstraction such that the designer need not manipulate the design at the lowest numbered part level, but can operate at varying levels of hierarchical abstraction and model fidelity;
- Develop practical and observable metrics of complexity to augment size, weight, power, and performance in informing design decisions;
- Enable rapid exploration of the design trade-space for high-fidelity requirements trade-offs; and
- Yield detailed system designs that are “correct-by-construction,” i.e., probabilistically verified for consistency, multi-mode interactions, and first-order performance characteristics across all the relevant physics domains (including embedded software).

The META tools will be embodied in an open-source research tool chain; an easy-to-use web-based tool with access to cloud-based high-performance computing capabilities aimed at a mass market; and a high-end tool suite based on state-of-the-art commercial PLM capabilities.

If META represents an analogue to EDA tools, then iFAB²⁸ is the foundry-style manufacturing capability. Once a given design is developed and verified, iFAB aims to take the formal META design representation and automatically configure a digitally programmable manufacturing facility, including the selection of participating manufacturing facilities and equipment, the sequencing of the product flow and production steps, and the generation of computer-numerically-controlled (CNC) machine instruction sets as well as human instructions and training modules. In essence, iFAB seeks to eliminate the learning curve in large-scale manufacturing in quantities of one.

Much like META, iFAB is predicated on detailed formal models representing the capabilities of various manufacturing machines and processes. By mapping these models into the same semantic domain as the vehicle design, iFAB can automatically constrain the design trade space such that designs that are not manufacturable in a given iFAB instantiation are automatically culled. Though we term iFAB a “foundry”--principally to differentiate it from a conventional factory that, at least in the defense world, tends to be a custom facility tailored to a specific product or small set of product variants--in actuality it is mostly an information architecture. Only the final assembly capability needs to be co-located under a single roof in anything resembling a conventional fabrication facility; the rest of iFAB can be geographically distributed and can, in fact, extend across corporate and industrial boundaries, united only by a common model architecture and certain rules of behavior and business practices. The

²⁸ Instant Foundry Adaptive through Bits (iFAB)

final assembly node of the iFAB facility for infantry fighting vehicles is currently slated to be at Joint Manufacturing & Technology Center at the Rock Island Arsenal.

The substantial time advantage which stands to be gained from META and iFAB is predicated on the existence of detailed models of components, of the environment (contexts), and of manufacturing equipment and processes. In the case of META, these models contain information on every behavior and modality of interaction (static and dynamic) that a component can exhibit, thereby affecting some other part of the system. This requires significantly more information than exists in most present-day component models, which are typically little more than performance curves and interface specifications. It requires a complete characterization of the desired interfaces as well as the undesirable or spurious interactions that a component can have, such as thermal, vibrational, or electromagnetic emissions. The META tools draw on a component model library which can include discrete “catalog” components, “rubber” or parametric component models where scaling behavior can reasonably be predicted, as well as “ghost” or hypothetical components which may not yet exist but could be developed if they prove useful in specific designs or in especially promising swathes of the design trade space.

Although for the purpose of the FANG vehicle, DARPA has embarked on the construction of model libraries through sponsored research, in the long run we envision the development of an industry consortium to promote and incentivize model development. An interesting example of such an incentive scheme is the European AUTOSAR²⁹ consortium, which includes automotive OEMs³⁰ and electronic component suppliers. Component suppliers publish detailed component models in a uniform modeling language to the consortium as a means of marketing their products to the OEMs.

If the analogue to the VLSI paradigm is borne out by META and iFAB, then the decoupling of design and manufacturing promises to open the aperture for innovation by reducing the barrier-to-entry associated with the capital requirements of a captive fabrication facility to support integration and resultant design iteration. This holds the promise of moving the defense industry from dozens of innovators³¹ to, perhaps, thousands. However, DARPA has embarked on an experiment to further increase this number by several orders of magnitude; we call this *democratizing innovation*. Our

²⁹ AUTomotive Open System ARchitecture (AUTOSAR)

³⁰ Original Equipment Manufacturers

³¹ If we consider that each sector of the defense industry has 3-5 dominant players, with an elite design team for advanced concepts and new products number around a dozens, the total number of brains contributing to the development of next-generation DoD systems numbers fewer than a hundred. Most of these are experienced designers, selected for seniority and perhaps having seen a defense product all the way from concept to fielding in the course of their career (if they are lucky). Unsurprisingly, this arrangement is not conducive to radical innovation and the idea pool is shockingly small given the size and importance of the procurements drawing upon it.

approach is inspired by several DARPA crowd-sourcing experiments. The first, the DARPA Network Challenge (or the Red Balloon Challenge) offered a prize to the first person or team to correctly identify the locations of ten moored, 8-foot, red weather balloons at various fixed locations in the continental United States. The prize was collected in under nine hours by an MIT team that constructed a social network with a geometric referral incentive scheme for divvying up the prize money and aggregating information on balloon locations. The Network Challenge demonstrated the power of large, heterogeneous, loosely aggregated networks of people united by a common incentive structure.

The second, the XC2V³² design challenge was a prize award offered to a social network of automotive enthusiasts for the best design of a vehicle body for combat reconnaissance and combat delivery & evacuation missions. The social network was equipped with a simple collaboration environment that enabled designers to receive feedback from the crowd and leverage each other's ideas and concepts. The contest yielded over 150 viable designs in a span of six weeks, of which several dozen were deemed extremely innovative by experts from the user community. The XC2V experiment demonstrated the applicability of crowd-sourcing techniques to military missions, the potential for significant timeline compression, and the value of heterogeneity in the innovation talent pool.

The third crowd-sourcing experiment, called Foldit, is an online game that challenges users to fold proteins (a notoriously challenging problem). The game has attracted thousands of players and has yielded some scientifically significant results.³³ The game has shown the existence of outlier savants--small numbers of individuals with cognitive ability to fold proteins that is five or more standard deviations above the mean. Interestingly, most of these individuals had no formal background in biochemistry and no other apparent indicia of their hidden talent. We can postulate the existence of such hidden 5σ -savants in other domains of expertise. It only takes the discovery of a handful of individuals of such outstanding capacity to alter the course of history.

Based on these early lessons in crowd-sourcing, we are developing *vehicleforge.mil*, an open-source collaboration environment to enable crowd-sourcing of military vehicle designs. *vehicleforge* is structured much like open-source software collaboration (or "forge") sites such as *sourceforge.net*. Such collaboration approaches, however, have not been previously applied to the design of physical systems due to the impossibility of change propagation across design elements (e.g., how did a change to one drawing affect an entirely different and superficially unrelated part of the system?) and the challenge of rapidly predicting the impact of design changes on performance (e.g., did a

³² Experimental Crowd-derived Combat-support Vehicle (XC2V)

³³ F. Khatib, F. DiMaio, Foldit Contenders Group, Foldit Void Crushers Group, et al., "Crystal structure of a monomeric retroviral protease solved by protein folding game players," *Nature Structural and Molecular Biology*, Vol. 18, 2011, pp. 1175-1177.

design change improve or worsen performance, or make the system altogether cease to function?). META provides a solution to both of these problems. It serves both to model and propagate all modalities of interaction among components, and to make first-order performance estimates for a system subjected to a given context or environment model. META, in essence, acts as the equivalent of a software compiler for physical systems.

vehicleforge serves as both a model library and design repository, and is replete with features familiar to open-source software developers such as check-in/check-out, version control, design branching, etc. It enables the customization of intellectual property and security access policies for a given design space, and offers reputation-based credentialing and provenance algorithms for users, components, and designs. *vehicleforge* is a treasure trove of interesting policy challenges vis-à-vis export controls, clickwrap licensing of intellectual property, and protection of potentially sensitive details of the design. It confronts us with strategic questions such as: what balance between secrecy and agility provides the greatest competitive advantage to our warfighting capability against conventional and non-conventional adversaries? Nonetheless, if the vulnerability and timelines associated with proprietary versus open source software are any indication, *vehicleforge* promises to make a significant contribution both to the robustness, quality, and timeliness of military vehicle designs.³⁴

META, iFAB, and *vehicleforge* are three elements of infrastructure that will be tested at scale in the development of the FANG vehicle. The FANG design will be developed through a series of prize challenges, culminating in a \$2 million award for the best total vehicle design. Design submissions must be encoded in the formal META modeling language, but can emanate from traditional defense industry, networks of smaller businesses using *vehicleforge* as a collaboration and integration environment (thus obviating the need for a systems integrator), entirely open crowd-sourced communities, or hybrids of these approaches. Designs are measured against published context/environment models, such that the scoring of winners is an entirely objective process. The use of prize challenges is DARPA's attempt to move closer to a make-before-buy paradigm for the procurement of defense systems, as well as to open the aperture to non-traditional offerors such as loosely-aggregated networks of businesses or individuals. The winning FANG design will be manufactured in iFAB and evaluated against the Marine Corps' ACV prototype in side-by-side operational testing. In the interest of providing a significant incentive beyond the modest prize award to the FANG design community, the ACV program will incorporate the FANG vehicle in its selection of an ACV design for full-rate production.

The final element of the AVM portfolio is an outreach program aimed at high school students. The MENTOR³⁵ effort will deploy 1,000 3-D printers in various material

³⁴ See, e.g., M. Delio, "Linux: Fewer Bugs Than Rivals," *Wired*, 14 Dec. 2004.

³⁵ Manufacturing Experimentation and Outreach (MENTOR)

chemistries to as many schools, network them into a distributed manufacturing capability supported by simple design collaboration tools, and exercise this architecture with a series of challenges to build systems of modest complexity such as simple robots, go-karts, etc. MENTOR seeks to create a microcosm of the greater AVM portfolio in a manner that is accessible to youths so as to inspire a next-generation cadre of manufacturing innovators.

Concluding Thought

Our species' post-Industrial Revolution technological progress can be neatly binned into several epochs. The 19th century was defined by our ability to harvest abundant energy. The 20th century was a century defined by our command of bits, of the world of information. With nascent advances like model-based design synthesis, direct digital manufacturing, and synthetic biology that bridge the divide between bits and atoms, the 21st century promises to be one defined by our mastery of matter.³⁶ Today, it is primitive. To adapt a Hobbesian metaphor, traditional industrial manufacturing processes are nasty, brutish and long. They are also rigid--it is difficult to adapt them to new requirements. A host of innovations are now being demonstrated that can transform our ability to make things. The issue is whether the complexity of defense systems can be accommodated by these faster, cheaper and more efficacious approaches. DARPA's work aims to meet this challenge.

³⁶ Paraphrased from an observation by MIT's Tom Knight.

APPENDIX 2:
DEPICTION OF THE META-IFAB INTEGRATED TOOL CHAIN

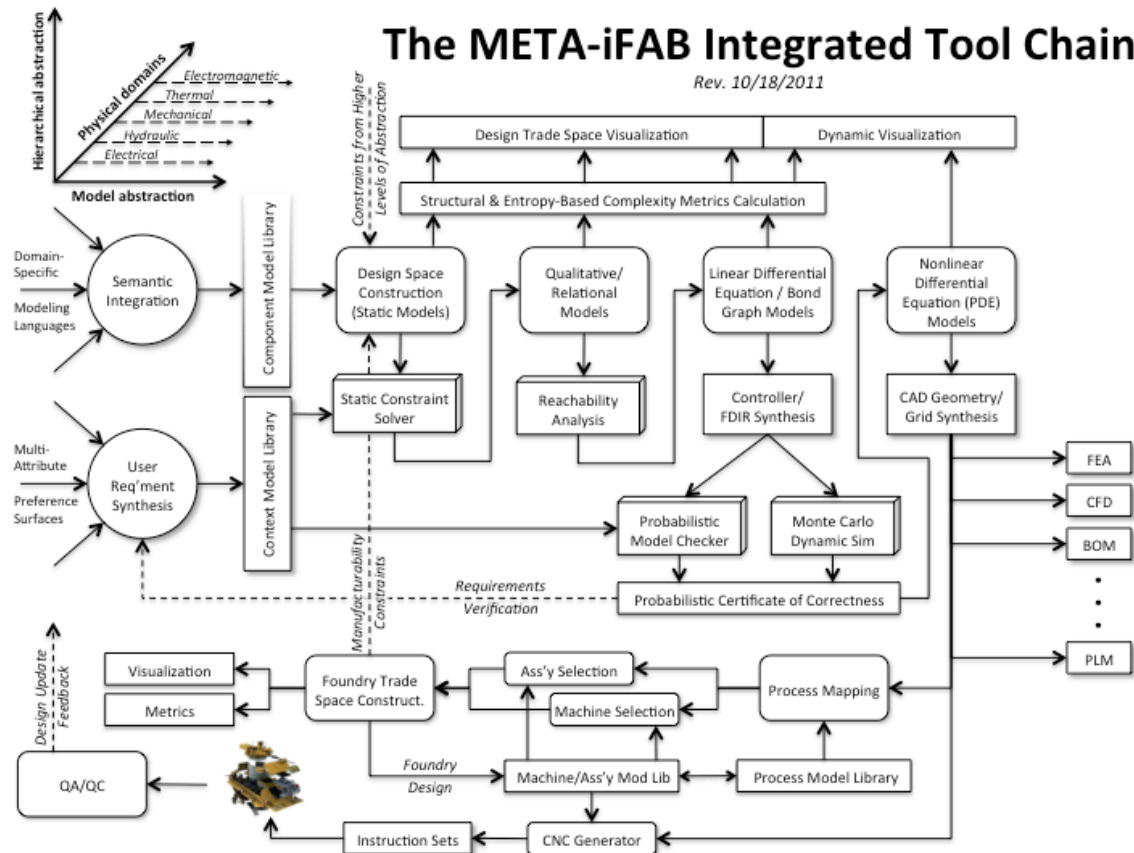

Figure A2.1: The META-iFAB Integrated Tool Chain

The integrated META and iFAB software tool chain, as presently envisioned, is depicted in Figure A2.1 above. The META tools have been under development since Fall 2010, although they leverage almost two decades of research in cyber-physical systems and formal verification methods. The META tools are presently at approximately TRL 5-6 and are anticipated to be at TRL 6-7 by the time they must be deployed for the first FANG challenge, with eventual maturation by the time of the Full Vehicle Challenge to TRL 7-8.³⁷ DARPA is pursuing three parallel instantiations of the META tool chain. The first, the so-called “research core,” is being led by Vanderbilt University (in collaboration with MIT, PARC, SRI, and several other partners) and encompasses most of the functionality depicted in Figure A2.1 in a free, open-source implementation. The second, led by a recent spin-off from Xerox PARC called CyDesign Labs, is a highly productized, web-based (software-as-a-service) version aimed at mass

³⁷ TRL refers to Technology Readiness Levels as defined in, e.g., *Better Management of Technology Development Can Improve Weapon System Outcomes*, Report No. GAO/NSIAD-99-162, Government Accountability Office, 1999, App. I, available at: <http://www.gao.gov/archive/1999/ns991620.pdf>

market adoption that somewhat reduces the feature set of the research core in exchange of ease of use. The third, led by Dassault Systèmes, is derived from Dassault's existing high-end commercial CAD/PLM tool suite with the addition of probabilistic, simulation-based verification capability across multiple physical domains.

Current iFAB developments, which have been ongoing since Summer 2011, are aimed at several technological challenges that underlie the iFAB concept. These include reasoning about shape, foundry optimization, modeling of humans, and the development of a parametric manufacturing process model library. The iFAB tools presently exist only as a loose aggregation of capabilities supplied by multiple performers without significant integration. Several critical gaps still exist in the end-to-end iFAB functionality, and these are expected to be filled by the iFAB Foundry performer.³⁸ Principal gaps include the ability to perform kinematic modeling of a broad range of manufacturing machines and processes (including humans), the handling of tolerances in a systematic manner, the homogenization of semantics across various manufacturing process models, and the mechanisms for manufacturability feedback to the META tools. The iFAB tool suite is presently at TRL 3-4 and expected to be rapidly matured to TRL 5-6 by the first FANG challenge, and TRL 7-8 by the Full Vehicle Challenge.

³⁸ <https://www.fbo.gov/spg/ODA/DARPA/CMO/DARPA-BAA-12-14/listing.html>

APPENDIX 3: EXAMPLE META COMPONENT PACKAGE

A system designer utilizing the META-iFAB toolchain relies upon the C2M2L libraries to provide component models upon which to operate and build their design, context models against which to test their design, and manufacturing process models to provide manufacturability and design feedback to inform and enhance their design. As this design is built, it is ultimately compiled into a META data package transportable to the iFAB information architecture for interpretation and physical instantiation. What follows is an example of how C2M2L models are incorporated by META into the final META package, as realized by Vanderbilt University (a current META-X performer).

The META Component model package contains a set of domain models (i.e. CAD, Dynamics, Cyber, etc.) packaged together and described using an XML (extensible markup language) component descriptor. The XML component descriptor constitutes a wrapping model that captures the integration interfaces of a component, along with embedded links to the domain models, as well as the relevant properties and parameters of the components. The partial schema for the XML is shown below with a UML (unified modeling language) class diagram, followed by an example component model package.

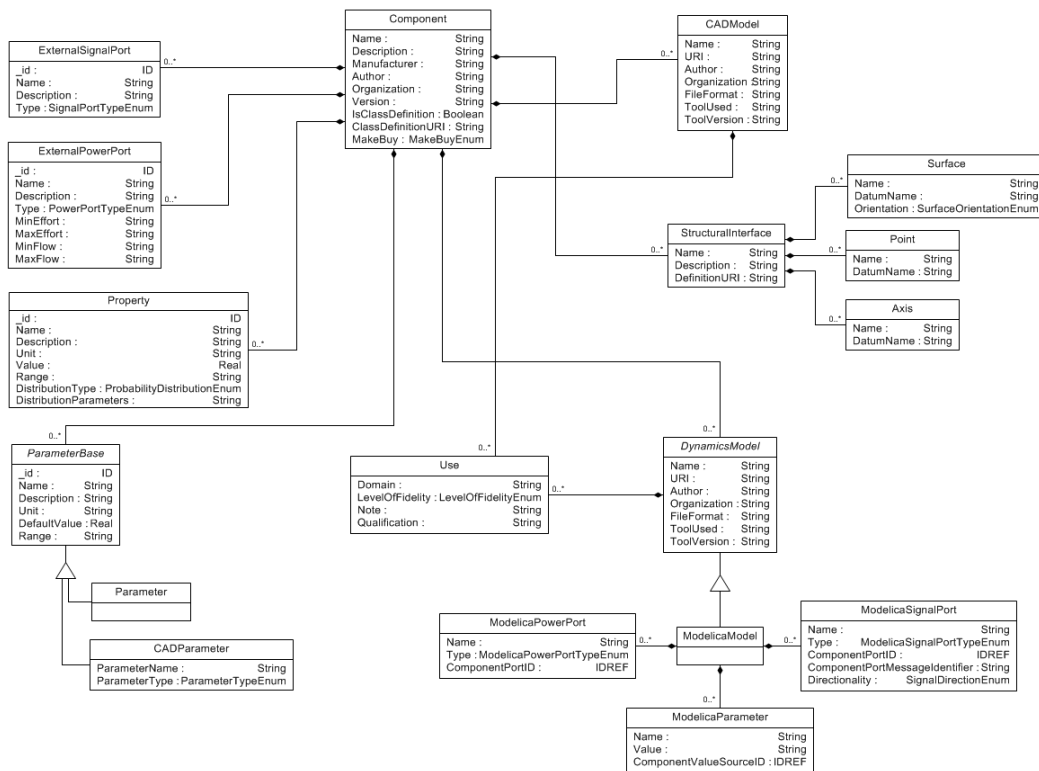

Figure A3.1: Partial Schema of the META Component Descriptor XML

An example Diesel Engine packaged as a META component is described below. The component developer creates dynamics models of the Engine using one of many dynamics modeling languages such as Modelica, Hybrid Bond Graphs, Simulink, etc.

The component developer also creates CAD model of the component, and associates datum with the structural interfaces in the CAD model. The component developer then creates the wrapping XML that packages these component models, specifies the key properties and parameters, and integration interface of the component.

```
<?xml version="1.0" encoding="utf-8"?>
<Component Description="Sample Engine" Name="SE1" Manufacturer="Supplier"
Author="Author1" Organization="Organization1" Version="1" IsClassDefinition="false"
ClassDefinitionURI="DieselEngine.xml">
  <Property Name="Max Power" Unit="kw" Value="335" _id="ID7" />
  <Property Name="Max RPM" Unit="rpm" Value="2300" _id="ID8" />
  <Property Name="Peak Torque" Unit="Unit3" Value="1364" _id="ID9" />
  <Property Name="Weight" Unit="kg" Value="680" _id="ID1" />
  <Property Name="Height" Unit="mm" Value="1070" _id="ID3" />
  <Property Name="Depth" Unit="mm" Value="1245" _id="ID4" />
  <Property Name="Width" Unit="mm" Value="680" _id="ID5" />
  <Property Name="Mount To Drive Centerline" Unit="mm" Value="207" _id="ID10" />
  <Property Name="Front Mount To Bell Housing Distance" Unit="mm" Value="1104.24976"
_id="ID6" />
  <CADModel Name="CAD Model" Author="Author1" Organization="Organization1"
URI="CAT_C9">
    <Use LevelOfFidelity="Low" Domain="Geometric" Note="simple block"
Qualification="Used in block layout models in the past" />
    <Use LevelOfFidelity="4" Domain="Thermal" Note="" Qualification="Used
successfully for heat distribution study" />
  </CADModel>
  <StructuralInterface Description="Description1" Name="BellHousing"
DefinitionURI="SI_Def://SAE_Standards/SAE_1">
    <Axis DatumName="DRIVE_AXIS" Name="Drive Axis" />
    <Surface DatumName="FLYWHEEL_HOUSING_MNT_SURF" Name="Flywheel Housing Mount
Surface" Orientation="SIDE_A" />
    <Surface DatumName="DRIVE_CLK_PLANE" Name="Rotational Alignment Surface"
Orientation="SIDE_A" />
  </StructuralInterface>
  <ModelicaModel URI="Model://Modelica/Mechanical/DieselEngine" Name="EngineModel"
Author="Author1" Organization="Organization1" FileFormat="MO" ToolUsed="Dymola"
ToolVersion="X.Y">
    <ModelicaParameter Name="MaximumPower" ComponentValueSourceID="ID7" />
    <ModelicaParameter Name="FuelEfficiency" Value="0.023" />
    <ModelicaSignalPort Name="Throttle" Type="Integer" Directionality="Input"
ComponentPortID="ID16" ComponentPortMessageIdentifier="ENGINE_THROTTLE"/>
    <ModelicaPowerPort Name="Rotational Power Out" Type="Rotational"
ComponentPortID="ID11" />
    <ModelicaPowerPort Name="Fuel Input" Type="Hydraulic" ComponentPortID="ID12" />
    <ModelicaPowerPort Name="Exhaust Out" Type="Pneumatic" ComponentPortID="ID13" />
    <ModelicaPowerPort Name="Coolant In" Type="Hydraulic" ComponentPortID="ID14" />
    <ModelicaPowerPort Name="Coolant Out" Type="Hydraulic" ComponentPortID="ID15" />
  </ModelicaModel>
  <ExternalPowerPort Name="Rotational Power Out" Type="Rotational" ID="ID11"/>
  <ExternalPowerPort Name="Fuel Input" Type="Hydraulic" ID="ID12"/>
  <ExternalPowerPort Name="Exhaust Out" Type="Pneumatic" ID="ID13"/>
  <ExternalPowerPort Name="Coolant In" Type="Hydraulic" ID="ID14" />
  <ExternalPowerPort Name="Coolant Out" Type="Hydraulic" ID="ID15" />
  <ExternalSignalPort Name="CAN Bus" Type="CAN Bus" Description="" ID="ID16"/>
</Component>
```

Figure A3.2: META Component Descriptor for a Diesel Engine component

The component package is curated and represented within the META language (Figure A3.3), for use in the META toolchain.

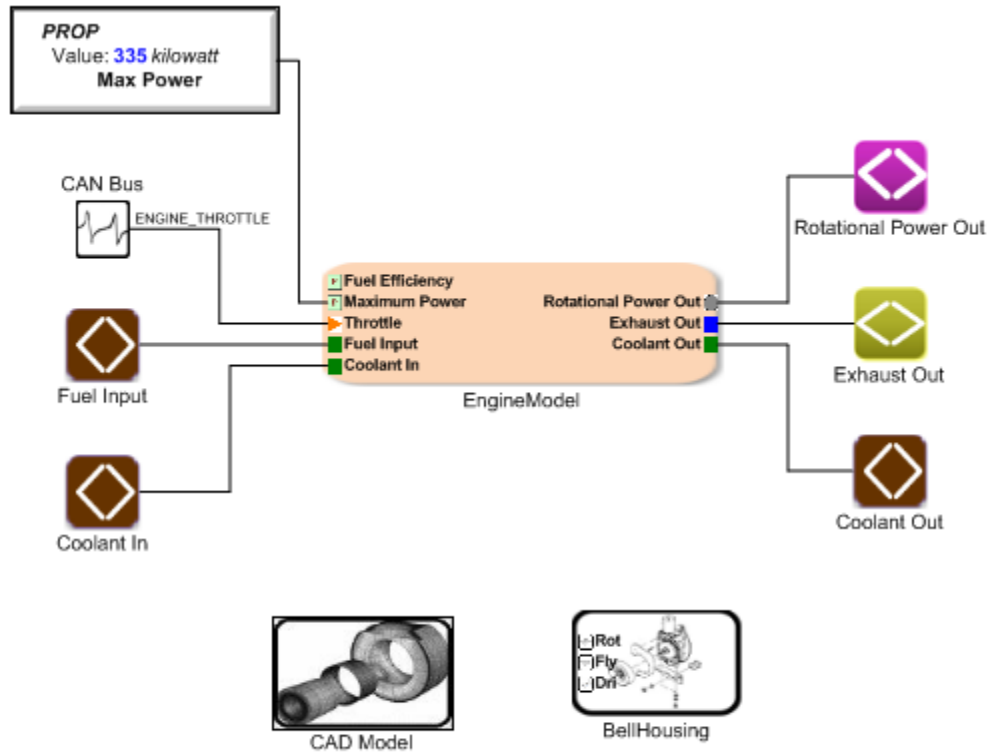

Figure A3.3: Diesel Engine component represented in the META CyPhy Language

APPENDIX 4. MODEL CURATION

With component, context, and manufacturing models being generated from multiple C2M2L performers (and ideally many industry sources in the long term), it is essential that these models be ‘curated’ such that they are consistently utilizable by the META-iFAB toolchain. This appendix describes C2M2L curation in terms of the use cases that will be supported by the Intentional Software Corporation AVM C2M2L Service (contracted as part of the C2M2L-1 TA4 effort). It also provides information about Intentional’s plans for managing metadata/data relationships via strong identities for document entities.

Use Cases

1. Consumers publish metadata specifications, which provide the basis for model contracts (as defined below).
2. Producers search for contracts to support with their models.
3. Producers publish models of components, contexts, and manufacturing capabilities that fulfill contracts.
4. Consumers search for models that fulfill their specifications and that match their design requirements.
5. Consumers/Producers curating the C2M2L Repository.

NOTE: Any reference to ‘model’ below should be interpreted to mean a multi-model representation of an entity at potentially several different levels of abstraction and fidelity.

Consumer: Publish Metadata Specifications and Contracts

Consumers (or producers in the consumer role) are able to accurately and adequately describe their intention by defining *contracts*. Contracts express a synthesis of consumer expectations for model content, quality, and fidelity. Consumers are thus in control of the organization of C2M2L. The best way to achieve this control, “curation by the crowd,” is to enable consumers to publish metadata specifications into C2M2L.

For example, each consumer may have different expectations for an “engine” component – the desired structural and behavioral models, the desired fidelity of the CAD models and a minimal set of engine metadata attributes. A consumer may include an interface to an abstract behavioral model of engine dynamics that each component model should fulfill. Additionally, each consumer may have different ways of describing where an engine fits into the taxonomy of a vehicle design. For example, is the engine being viewed as a structural element, a drive train element, or a part of the vehicle’s control network?

Such metadata specifications describe the requirements for the various classes of component, context, and manufacturing models and provides a means to organize these into the overall vehicle design and manufacturing ontology. Metadata specifications can also include parameterizable abstraction models with a semantically well-defined

interface that C2M2L models should support to help with semantics of model interaction. Therefore, the designer can mathematically analyze the potential seam between two components in a system design. Such metadata specifications are synthesized into contracts by the AVM C2M2L Service.

The AVM C2M2L service publishes contracts into the C2M2L Repository. It ensures that the contracts are included in the desired taxonomies in the ontology and that they are made available for producers searching for contracts to fulfill.

Producer: Searching for Contracts

Producers query the AVM C2M2L service to find the appropriate ontological identity for the model they wish to contribute to C2M2L. Once determined, the contract service produces a *synthesized contract* for the producer to fulfill. The synthesized contract is based on the collective input of consumers at the location where the ontological identities appear in the taxonomies that have been defined. The synthesized contract is the schema for the producer's model. It defines the required and optional attributes and sub-models expected for the kind of model the producer proposes to publish. Based on this contract, the contract service can provide each producer with an aggregate score for each proposed model. These scores may change over time as the desires of the consumer community change. It will also be possible to provide producers with a score based on a particular consumer's requirement if allowed by the consumer. Such functionality allows a producer to tune their offering to support either the community at large or a particular consumer.

Additionally, producers may wish to test their components against the abstraction models included in the synthesized contract. They can use the AVM Workbench to load the models into their specific modeling environment.

Producer: Publishing C2M2L models to vehicleforge.mil

When a producer wishes to publish a model to vehicleforge.mil, they start by creating or requesting a contract for their particular (component, context or manufacturing) model. The contract specifies the particular place in the C2M2L ontology and the metadata needed to publish the C2M2L model, for example, an electric motor. Initially, the contract might be minimal, but will grow over time.

If the producer decides to fulfill a contract with a model, but the model is not yet in an AVM-compliant language, she uses the AVM Workbench to create a new mapping to the META or iFAB languages. When the desired mapping has been completed, the producer runs a translation to generate the META or iFAB compliant model. The model is scored based on how well the contract is fulfilled.

Once a producer has evaluated her models against a synthesized contract, she can publish models that fulfill as many requirements as possible of that contract. This can be done by uploading C2M2L models directly using the AVM C2M2L Service or via the AVM Workbench. The advantage of the AVM Workbench is that it allows the producers to interact directly with the synthesized contract to evaluate their models and to view them translated into META and iFAB languages. The validation capabilities of the AVM Workbench provide real-time feedback to the producers about how well contracts are fulfilled by their models.

When the producer is satisfied with the mapping and rating, she can publish the models to the C2M2L library. The AVM Workbench invokes the AVM C2M2L Service that uses the metadata to place the C2M2L model in the ontology.

When a producer wants to provide a new version of an existing model, the AVM Workbench can identify the existing model and ensures that the new model will have matching unique identifiers so that consumers will be able to incorporate the updated models in their design at their discretion. Several versions of a model might exist in the repository simultaneously.

Consumer: Search, Retrieve and Use a C2M2L model

Once producers have published models to the C2M2L Repository, the models are available for use in META designs. When a consumer is interested in acquiring a C2M2L model, they have several ways of finding appropriate models. They can perform searches for models using string matching, attribute search and ontological search. They can also use contract-based search. These search capabilities use the AVM C2M2L service integrated in vehicleforge.mil.

Designers perform attribute searches as described in the next section. A collection of matching models will be identified and scored based on the search parameters and relevance to the designer's provided contract, if any (if not available, the aggregate score for other contracts can be substituted). When the designer is satisfied with the results, the Model Service (see Figure A4.1) synthesizes a C2M2L model for the designer to download.

When one or more candidate models have been identified, the consumer can download these models. If no candidate models have been identified, the consumer can leave their unfulfilled contract available for producers to evaluate and potentially bid on. The contracts will also contribute to future evolution of the metadata and ontology of C2M2L and the manner in which models are requested by the community in a dynamic way.

Once the consumer has obtained the model, she can incorporate the model in her design. If the model does not fit the specific tool being used, the consumer has the option to use the AVM Workbench to map the model to their desired design or manufacturing language using a custom Equivalence mapping.

Producer/Consumer: Curating the C2M2L Library

Both the producer and consumer, and anyone else in the AVM community with a vehicleforge.mil account, can participate in furthering the metadata and ontology being used to organize C2M2L models. Over time, depending on how the community evolves, there may be restrictions on who has trust and authority to change certain aspects (not unlike Wikipedia, for example). We expect these policies to be set by vehicleforge.mil.

We do believe that it is important that the ontology and metadata being used to facilitate model search and retrieval are dynamic and continue to evolve and be refined by consumers and producers alike. Especially, the development of synthesized abstraction models will evolve over time based on information available in the models producers publish and metadata specifications consumers submit.

Several overlapping taxonomies are expected (for example, one based on functional parts of a vehicle (drivetrain, chassis etc.), another for electrical/mechanical/electronics/software/components). Other taxonomies might even be relevant for sub groups within the AVM community, for example “in-house” components.

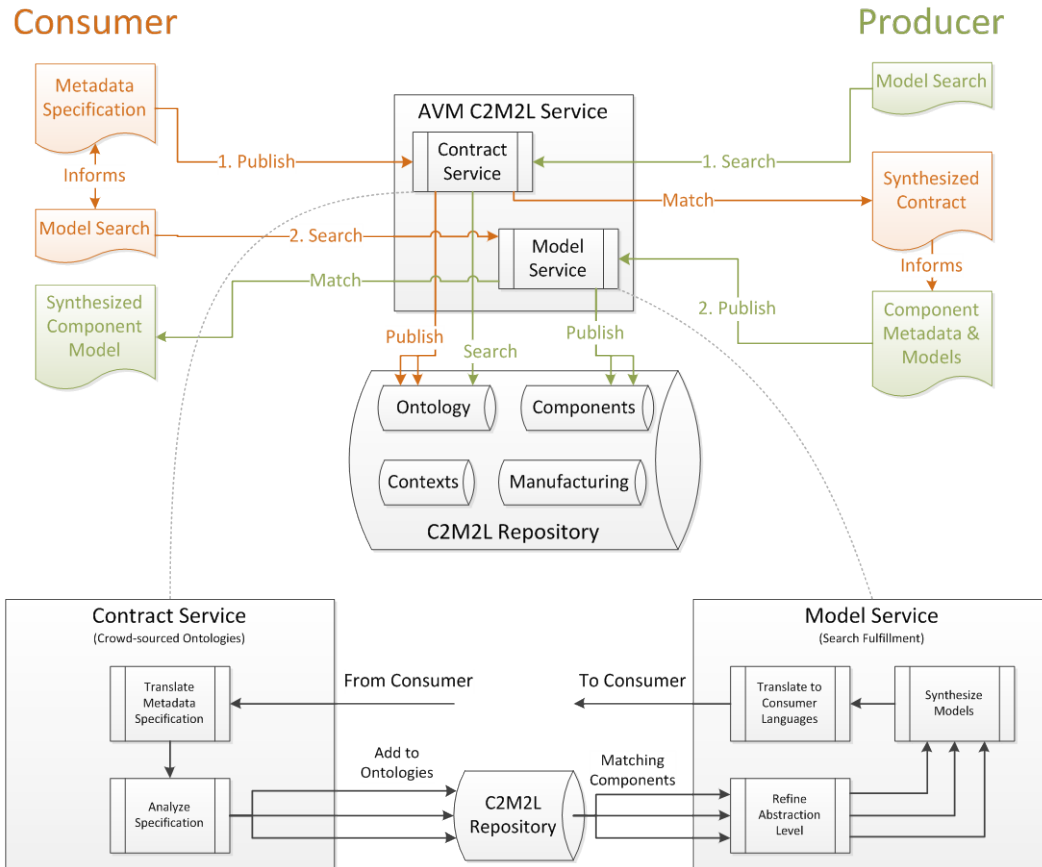

Figure A4.1 AVM C2M2L Service Use Cases

Metadata

Strong Identity

This section describes a user model for C2M2L content producers and consumers to create metadata specifications or envelopes for C2M2L models with supporting software. This section is not prescriptive about particular metadata required for particular design, context, or manufacturing queries.

The constituents of the C2M2L User Model are:

- A model editor and a metadata editor
- Suitable extension points and implementations

Or

- An integrated model and metadata editor.

Any metadata editor meeting this specification and the specification of the integrated META-iFAB toolchain should be considered acceptable input in a FANG challenge, including but not limited to CyPhyML, CyDesign, Intentional CLAMP, and Dassault's META toolchain.

This document will use the term "strong identity" to mean an identity assigned by an editor to a document element which:

- Is saved to disk in the editor's native format
- Can be programmatically obtained by the editor's native API
- Is unchanged by edits of sufficiently different elements of the document

Although outside the context of editors, a well-known example of strong identity is the use of globally unique interface identifier (IID) in the Component Object Model (COM) standard. A non-example of strong identity is STEP "Instance name" (e.g. #123 at the beginning of a line), since they are typically generated from consecutive integers and thus can change drastically from edit to edit.

Given strong identities for document elements, the metadata for C2M2L models will reliably describe authorship, ownership, capabilities, interfaces, and relationships between document elements.

Content of Component, Context, and Manufacturing Models

This section will provide some examples of what the consumer metadata specification and the model metadata envelope may include to paint a richer picture of AVM C2M2L Service capabilities.

For **Components**, the contract may require detailed semantic interfaces for how its model should integrate into a design. For a mechanical component, this might include:

- geometric dimensions and tolerances for interface seams,
- positions and dimensions of bolting holes; optional placement if available,
- required or optional presence of behavioral models and CAD models,
- parameters, e.g. hydraulic hose length; parameters might be continuous or discrete,
- physical properties like mass, torque, power consumption, and temperature range.

Electrical, electronic, software and other components will have different domain-specific component specifications. For example, CAN-bus standard compliant interfaces would exist for an electronic control unit (ECU) or a software API specification for software intensive components.

There may also be general component metadata that is the same across different component types, such as:

- materials and environmental information,
- vendor, vendor certifications, owned and contributing vendors, reselling vendors if different from manufacturing vendor, and contact information,
- cost, volume discount, and export restrictions,
- iFAB-specific parameters, probabilistic certificate of correctness, complexity metrics, but also community-derived information like component and vendor ratings, usage, date last sold, and feedback.

Context models should also be describable using metadata and taxonomies, perhaps around their specific usage and granularity. For example, some will reflect terrain constraints, while others might model chemical reactions like galvanic corrosion using the galvanic series tables and equations from MIL-STD-889.

Manufacturing models will start using taxonomies that are currently under development in the iFAB program. These taxonomies provide a good hierarchical starting point for machines and processes that will be available for the manufacturing models.

APPENDIX 5: COMPONENT MODEL EXAMPLE

This appendix provides an example of a component model as instantiated by Ricardo under the C2M2L-1 effort.

C2M2L Model Overview

- Consistent top level structure allows external tools to work with components:
 - View/modify component parameters, which may be more than simple values
 - Nominal, recommended, discommended, invalid values etc.
 - Uncertainties, tolerances, probability distributions
 - Change fidelity of embedded sub-models
 - Compose systems from multiple components by ensuring correct connections
- Component models hide (abstract) their implementation details by allowing for interaction only through a defined interface consisting of:
 - Static result values (e.g. weight or cost)
 - Connection ports
 - Adjustable parameters

Model Implementation

- The underlying physical model that actually provides the component implementation could be anything
 - C2M2L components will use **Modelica** models
- Implemented using an XML Wrapper file according to CyPhy³⁹ conventions containing:
 - Top level parameters
 - Physical interaction ‘ports’ (e.g. a torque flange or an electrical connector)
 - Structural interfaces (e.g. mounting points or flange location with bolt count and spacing)
 - Reference to an implementing dynamic physics based model(s)
 - Physics based models (e.g. Modelica, Adams, CFD, FEA, etc.)
 - Selected parameters and options of this model exposed at top level
 - Selected external ports (connections) are exposed at top level
 - Reference to CAD file describing the component
 - CAD model in some neutral format (TBD)
 - Selected parametric dimensions could be promoted to the top level

³⁹ CyPhy is part of the Vanderbilt META-X effort. See Appendices 2 and 3.

- Composition constraints exposed using a uniform structural interface (TBD)

Simple Model Example

- C2M2L component models will have a wider range of ports than a typical Modelica model as they are intended to work in multiple physical domains (possibly simultaneously)
- A typical Modelica engine model might only be able to predict amount of torque available versus engine speed and fuel flow rate – useful for predicting 0-60 times and fuel economy but cannot determine how large the radiator should be or the reaction forces on the mounts

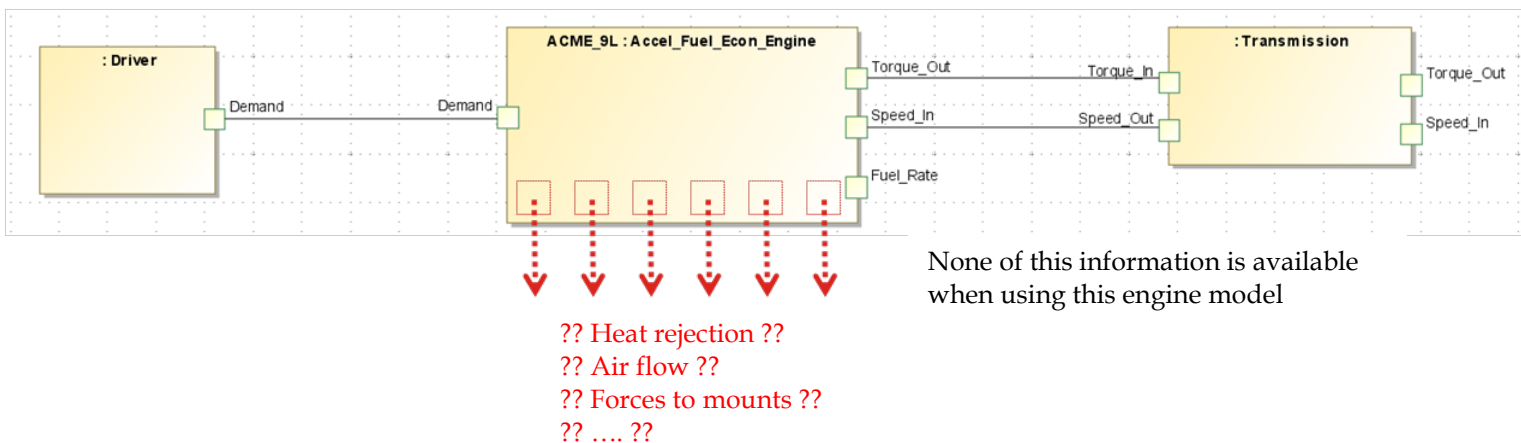

Figure A5.1 Simple model example

C2M2L Model Example

- A C2M2L engine model on the other hand will also be able to predict at additional ports:
 - Flow rates in & out of charge-air, fuel, coolant, oil, exhaust
 - Predict the heat added to coolant and oil flows
 - Forces/ displacements at mount points
- Thus interactions with other components (e.g. the aforementioned radiator) can be quantified

- Uses ports (e.g. fluid flow connectors) so that components can be connected to any other component that has a compatible port without knowing what that component is
- Every C2M2L component will include a potential set of connection points for including common interactions (e.g. mount points) and undesirable interactions (e.g. thermal, acoustic, chemical)
 - Acoustic, electromagnetic, chemical, thermal and mounting (vibration, reaction forces)
 - If the component doesn't support/require certain interactions the relevant port would be omitted

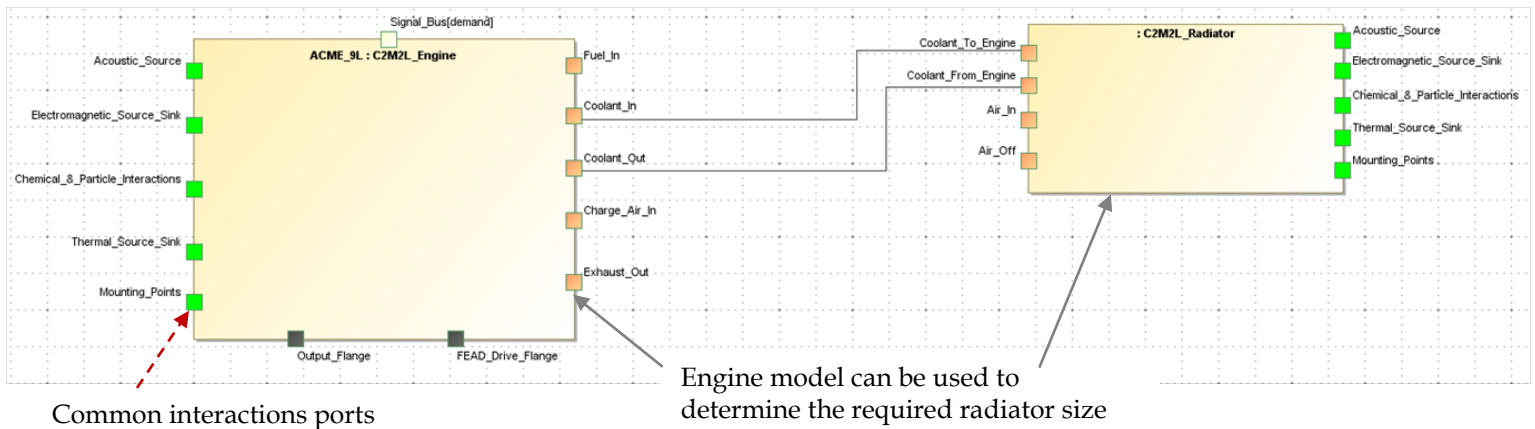

Figure A5.2 Model example

C2M2L Model Full Interaction Set

- A C2M2L engine model will interact with a wide range of components and potentially the environment context models as needed to simulate requirements
 - e.g. wouldn't need to model forces at engine mounts to simulate mobility or cooling system performance
 - Requirements will specify the simulation fidelity/features needed and models will specify if they satisfy this need

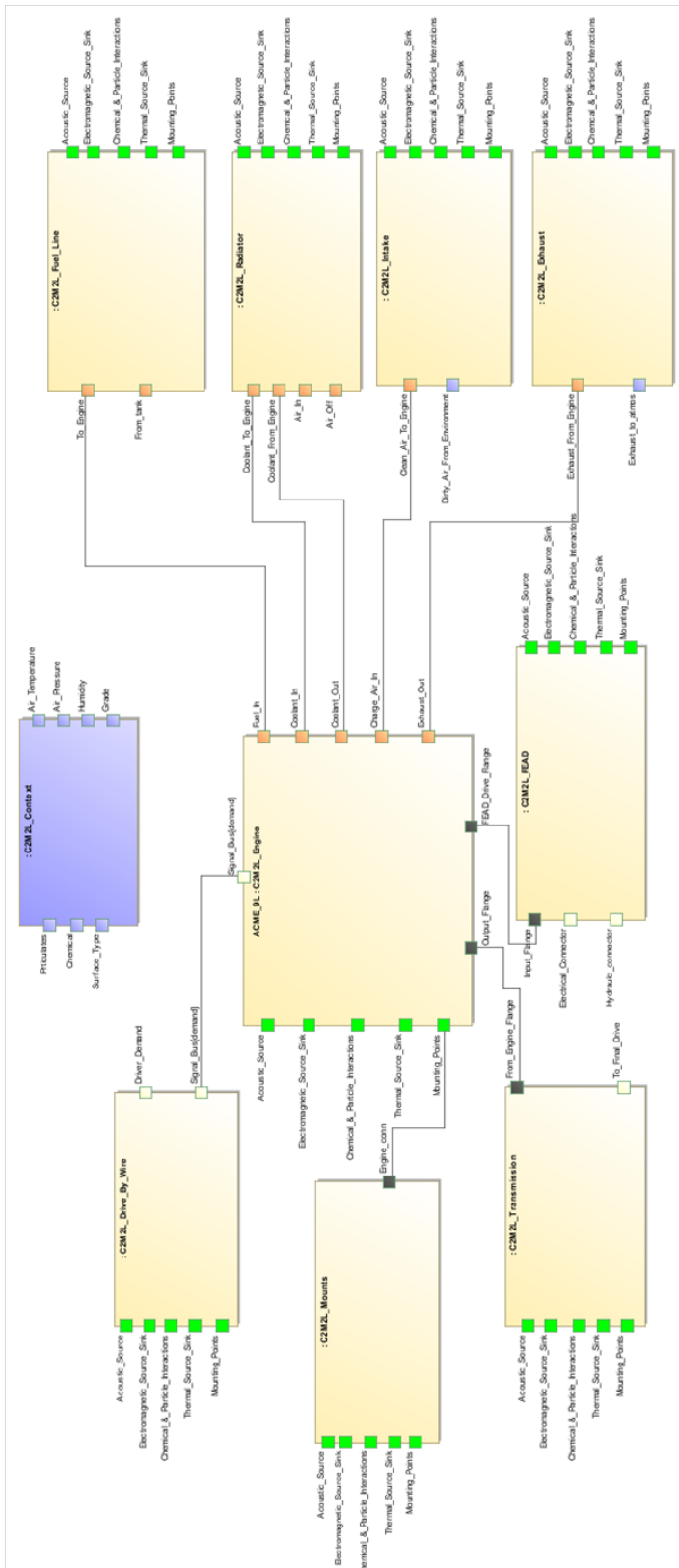

Figure A5.3 Full interaction set

APPENDIX 6: CONTEXT MODEL EXAMPLE

This appendix provides an example of the methodology for instantiating a context model as planned by BAE under the C2M2L-1 effort.

Context Models - anything outside of the design that can interact with the product, or with which the product can interact. For the purposes of the following discussion, the product is the design.

Creating Context Models

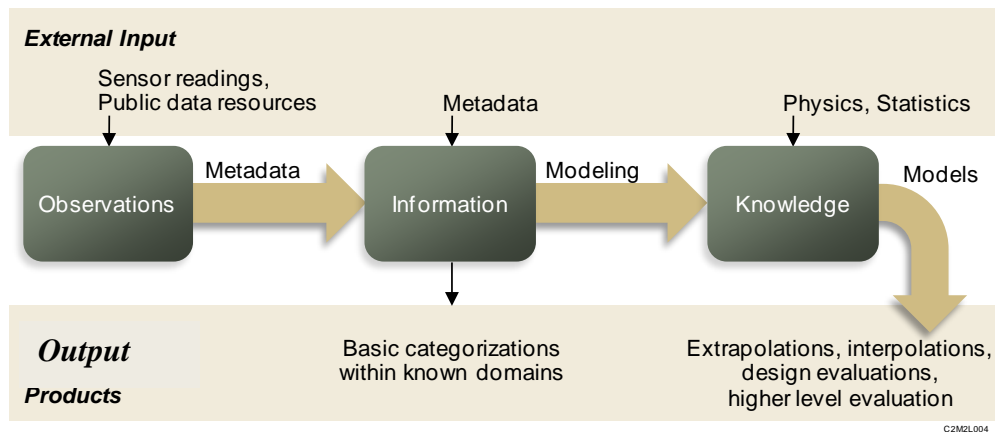

Figure A6.1 General Approach to Creating Context Models. By organizing the steps in processing data, scientists and engineers can recognize the required inputs each step of the way and take stock in products of the process.

The first step is collecting the initial data from observations and measurements. Step 2 is transforming the data to information. This transition from step 1 to 2 is called characterization. By characterizing the initial data, we may not understand the behavior but we have the information available for general comparisons⁴⁰.

Step 3 is transforming the information to real knowledge. The transition from step 2 to 3 is known as scientific modeling. By modeling, we can bring a much deeper understanding to the information at hand than what is available in lookup tables. We can extrapolate to regions outside the scope of our data ranges⁴¹. Given this capability, we can create context models for various physical phenomena and apply it to design verification.

Applying Context Models

⁴⁰ E.g., we can tell if an average terrain slope is steeper in one region than the next.

⁴¹ E.g., we can say how much steeper one area is than another and can explain why and have knowledge from which to process higher level inferences.

With reference to the design, one can think of the context models required to verify the operation of the design as being obtained via a controlled natural language query to obtain the models necessary to test the requirements - an example template of such a query is as follows:

1. Request a _____ representation for a _____ environmental characteristic given a specific location _____ and time _____

Then to verify the design in context, the following pattern is instantiated with the models returned from the query above:

2. For the models / representations returned, execute a _____ simulation / analysis to achieve a probability of _____ for criteria _____

For example, in the survivability domain, a query might be fashioned as follows:

Request a spectral shock representation for a non-military threat environmental characteristic given a typical Middle Eastern desert town in summertime.

Then, as stated above, the models would be used to verify the design as follows:

For the models/representations returned, execute a vibration simulation/analysis to achieve a probability of mission success for criteria small arms impact event.

Context models include, but are not limited to, the set of the following attributes.

- Position/ Location and Time
- Representation type - stochastic / deterministic
- Attributes of representation
 - Complexity
 - Fidelity
 - Assumption / Guarantee - preconditions, post-conditions, invariants
 - History / Pedigree (meta information)
 - Boundary condition constraints
 - Units / dimension
 - Scale / region
 - Precision / accuracy
 - Ergodic / state space
 - Complaint / dynamic
 - Accessible through HLA and/or FMI interfaces

References that indicate how one can create and utilize context models include:

- The oil conundrum - which gives a good overview of the methods to construction and application of stochastic context models.
- Military Standard 810F - which gives a good overview of the construction and use of power spectral density models

APPENDIX 7: MANUFACTURING PROCESS MODEL EXAMPLE

This appendix provides an example of the methodology for instantiating a manufacturing process model as planned by the Penn State Applied Research Lab (ARL) under the C2M2L-1 effort.

Penn State ARL is employing a modeling environment called OPCAT, which is based on the *Object-Process Methodology (OPM)*. OPM offers a generic ontology of stateful objects and processes and can be used to model systems and standards comprising hardware, software, regulations, and humans. While OPCAT provides a front-end capability for the development of formal graphics representing models, the primary benefit of OPM is export capability into a natural language, Object-Process Language (OPL), which is essentially an xml extension. The OPL will facilitate the population of the process models into a Manufacturing Model Library database and will also allow for simple interfacing with the ARL Penn State agent architecture. Finally, OPM is built in with abstraction-refinement mechanism, which essentially allows for hierarchical modeling to whatever level of detail is desired.

Below is an example process model developed using OPCAT for a Non-Cored Greensand Casting process. Many of the below figures shows a unique sub-process to the higher-level Non-Cored Greensand Casting process, thus illustrating the hierarchical aspect of the modeling methodology.

Figure A7.1 shows the top level Non-Cored Greensand Casting process along with several relations and links that are clearly described in Figure A7.16, a glossary of OPM process model elements.

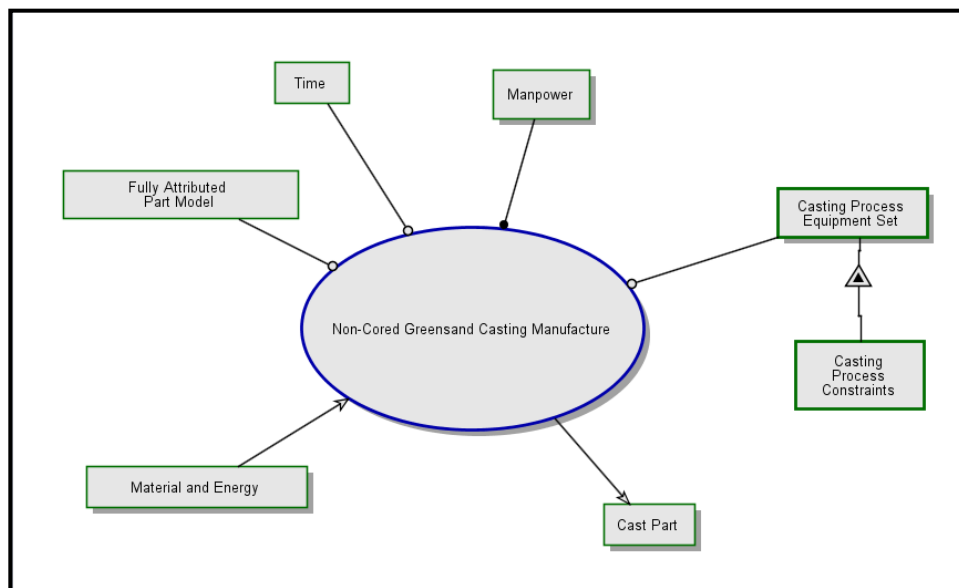

Figure A7.1: Non-Cored Greensand Casting Manufacture Process

Figure A7.2 demonstrates a unique characteristic in OPCAT called “in-zooming”, which allows for greater levels of process detail input for a particular process. In this case, you can see that Non-Cored Greensand Casting process consists of a Casting Development process, which produces a process plan and a pattern, which are inputs to the Casting Production process, which produces the casting, which is the input into the Casting Finishing process.

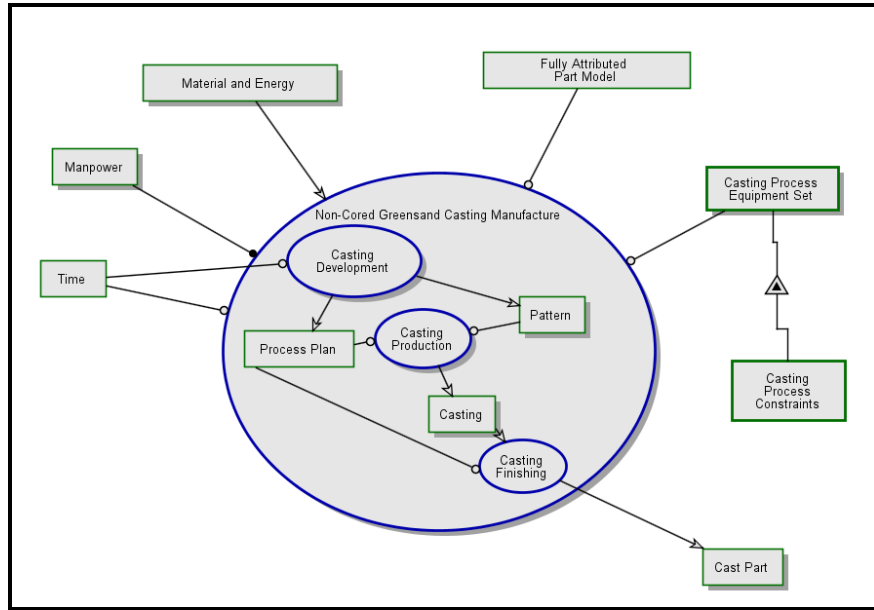

Figure A7.2: Non-Cored Greensand Casting Manufacture Process (Detailed)

Further in-zooming shows the details of the Casting Development process (Figure A7.3)

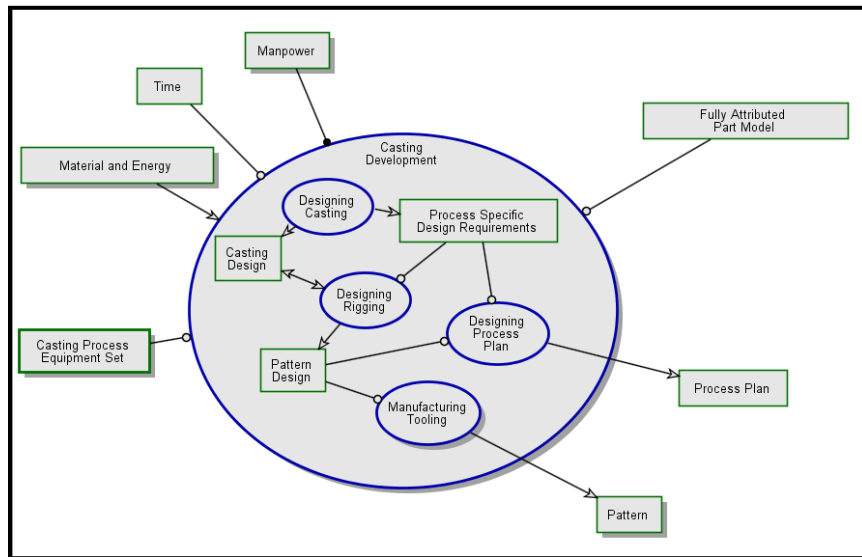

Figure A7.3: Casting Development Process

Figures A7.4-13 continue to in-zoom to more detailed sub-processes under the Non-Cored Greensand Casting Manufacture Process.

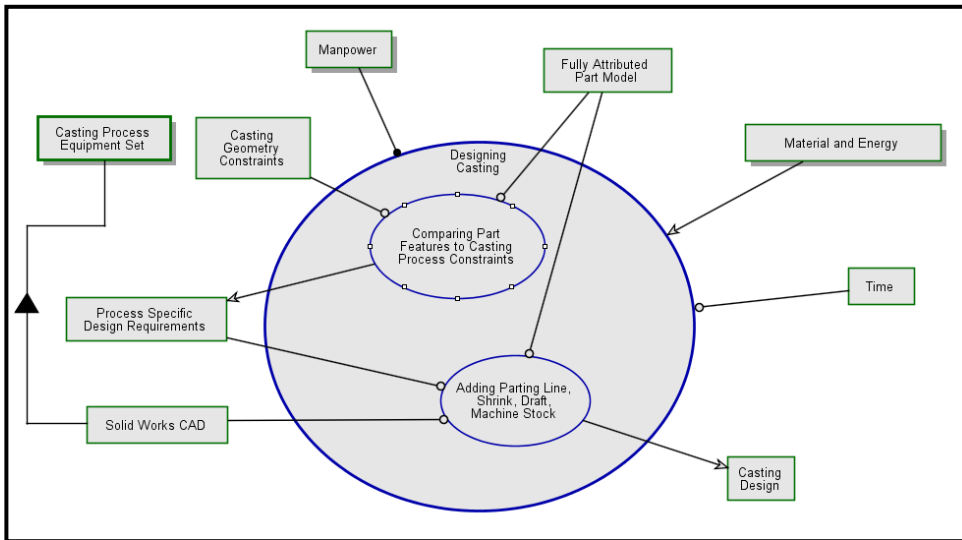

Figure A7.4: Designing Casting Process

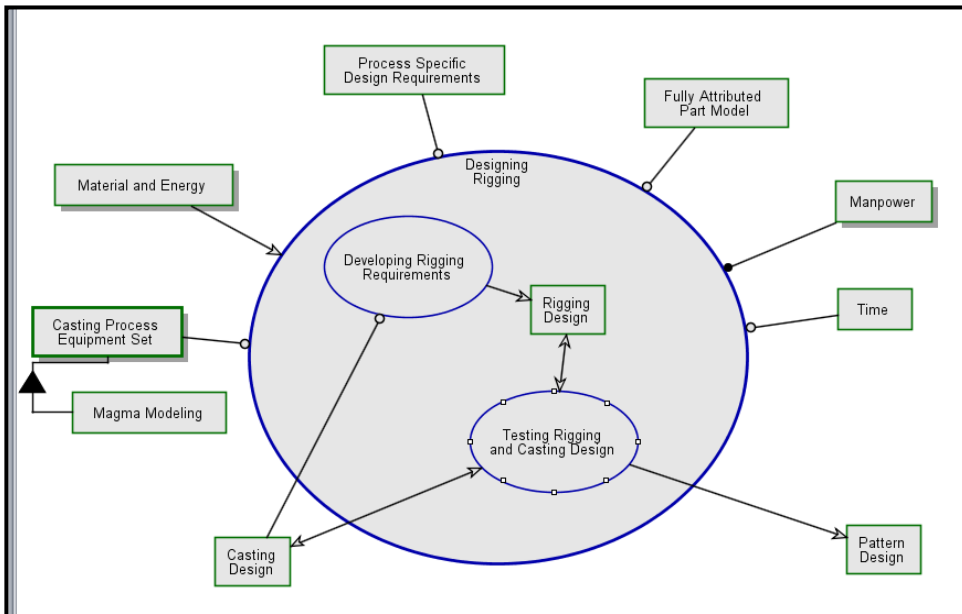

Figure A7.5: Designing Rigging Process

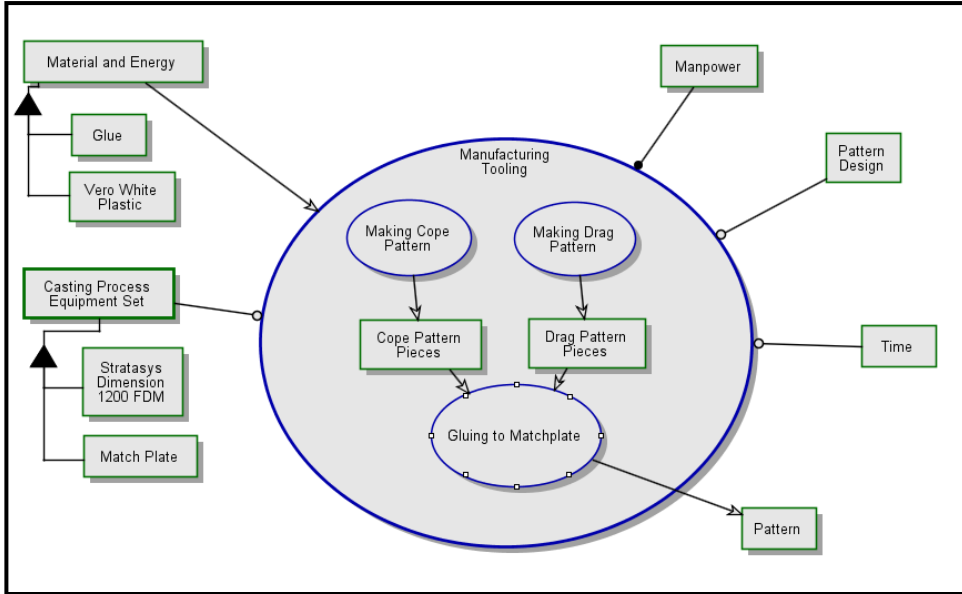

Figure A7.6: Manufacturing Tooling Process

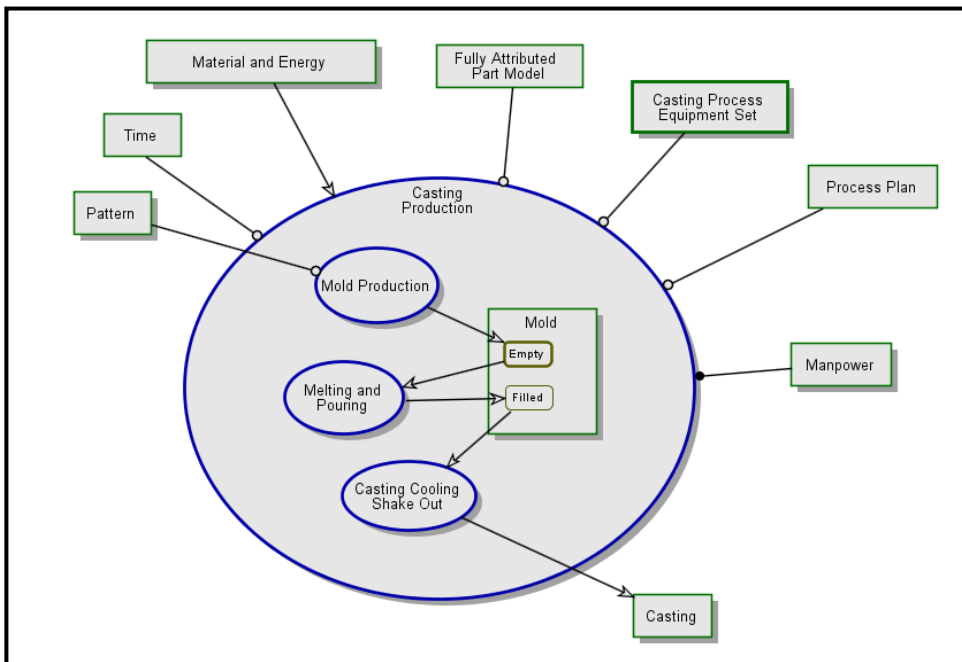

Figure A7.7: Casting Production Process

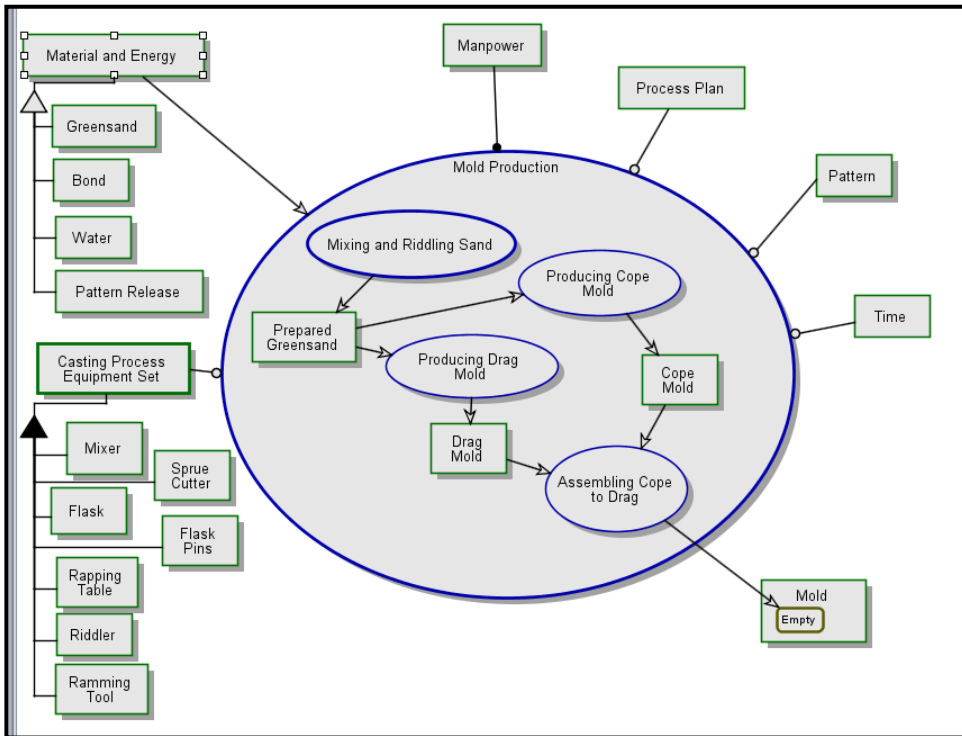

Figure A7.8: Mold Production Process

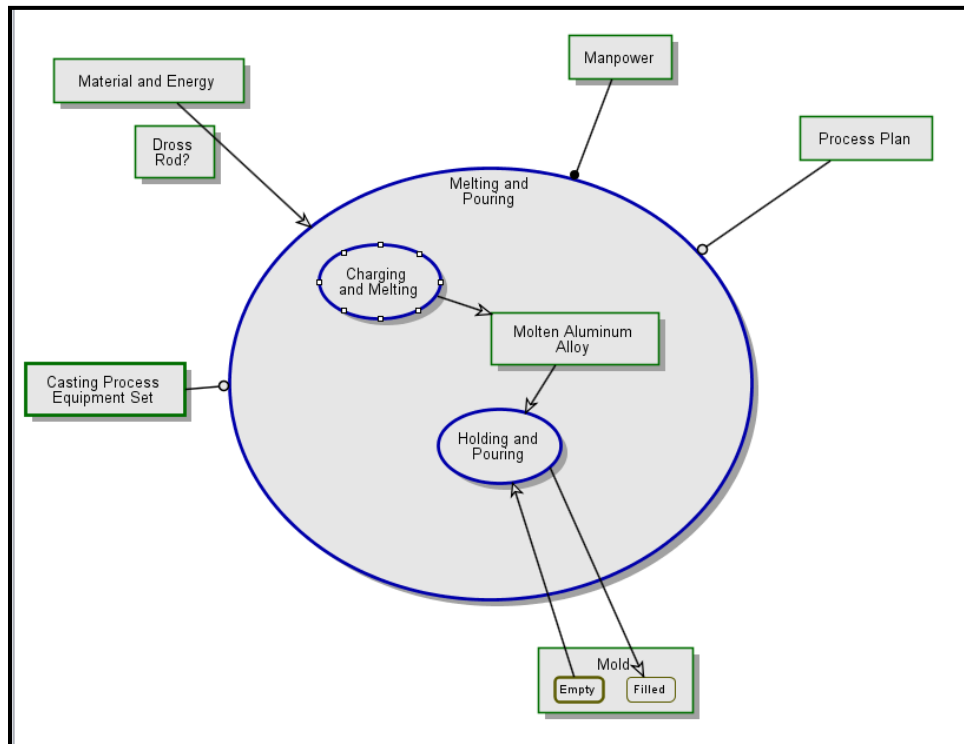

Figure A7.9: Melting and Pouring Process

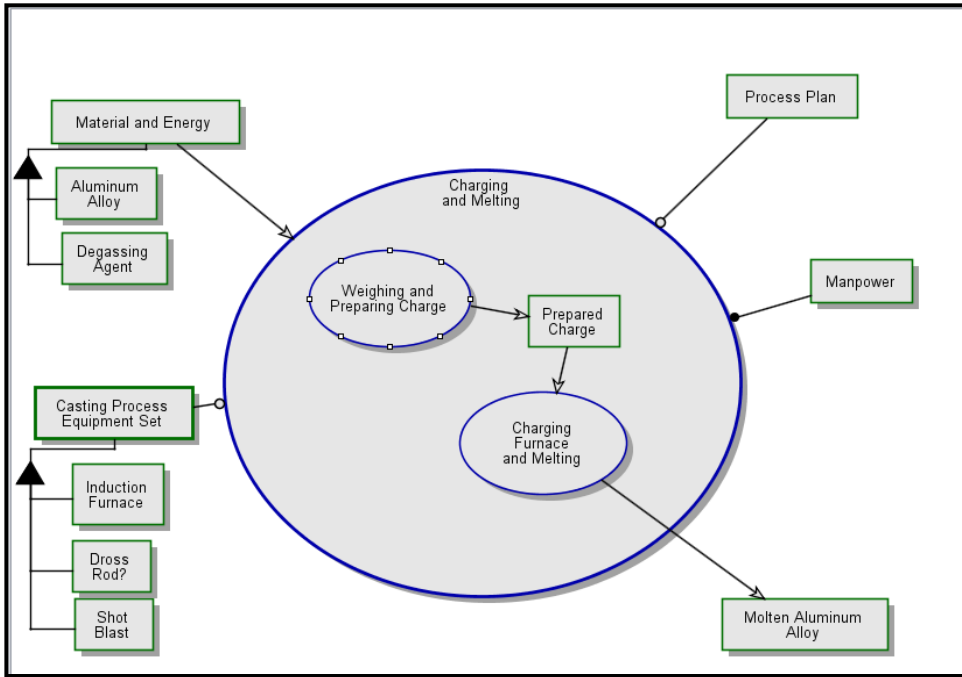

Figure A7.10: Charging and Melting Process

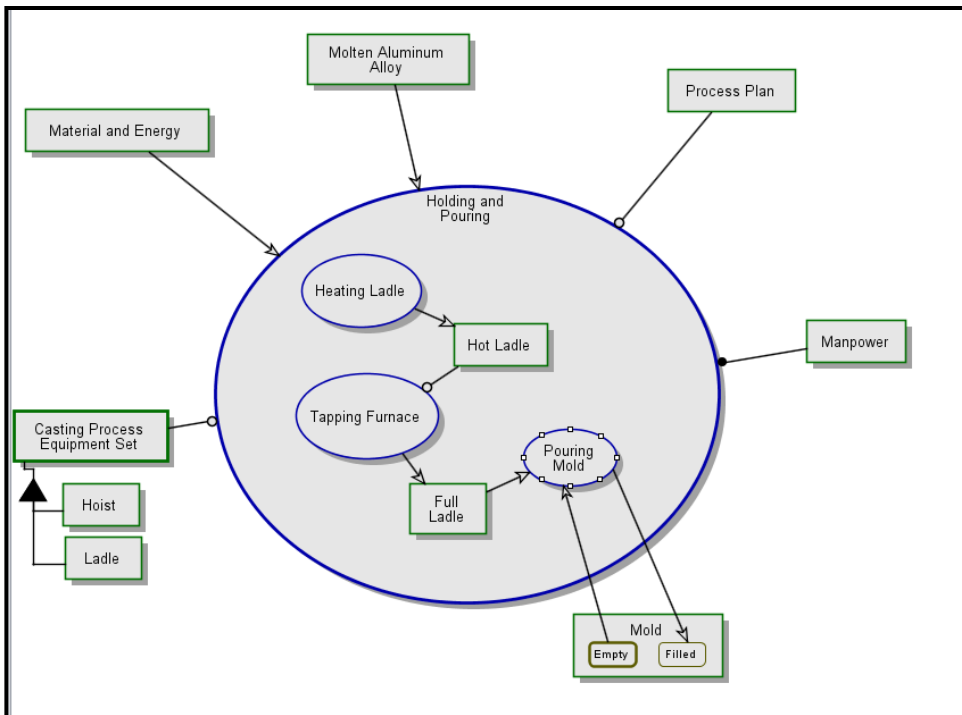

Figure A7.11: Holding and Pouring Process

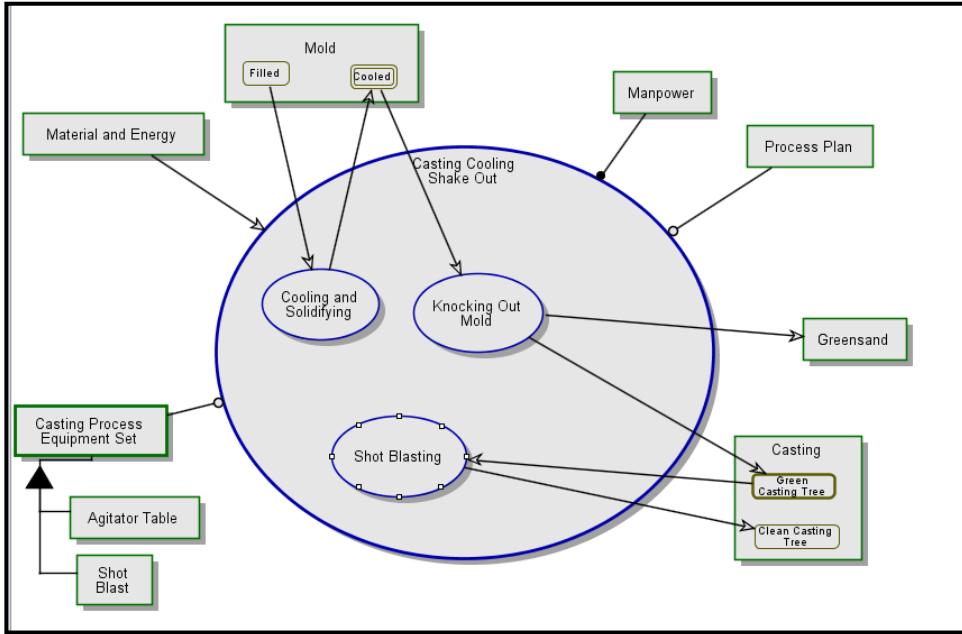

Figure A7.12: Casting Cooling and Shake Out Process

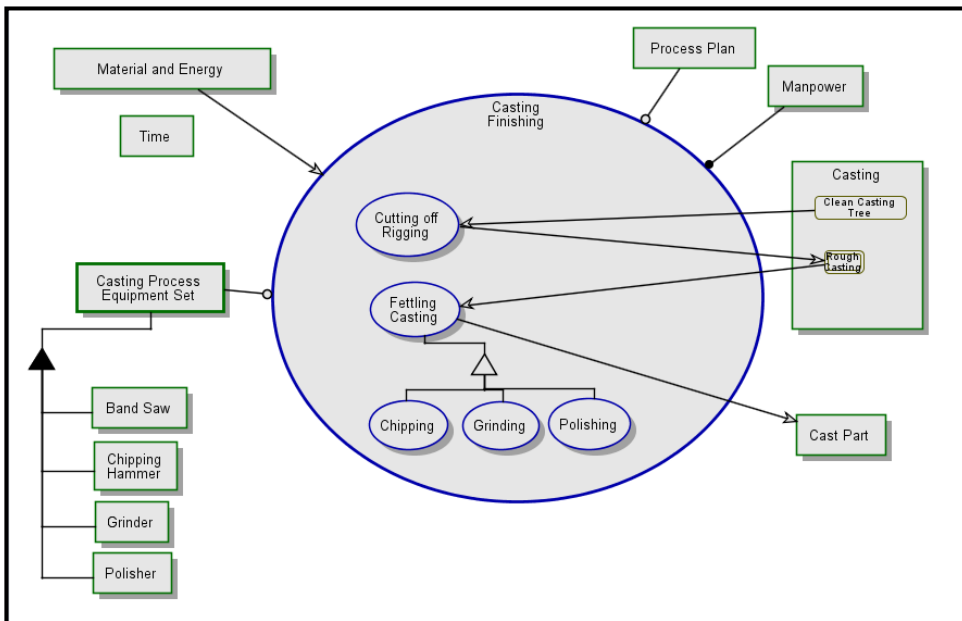

Figure A7.13: Casting Finishing Process

The OPM process models also allow for the definition of process constraints, as shown in Figure A7.14.

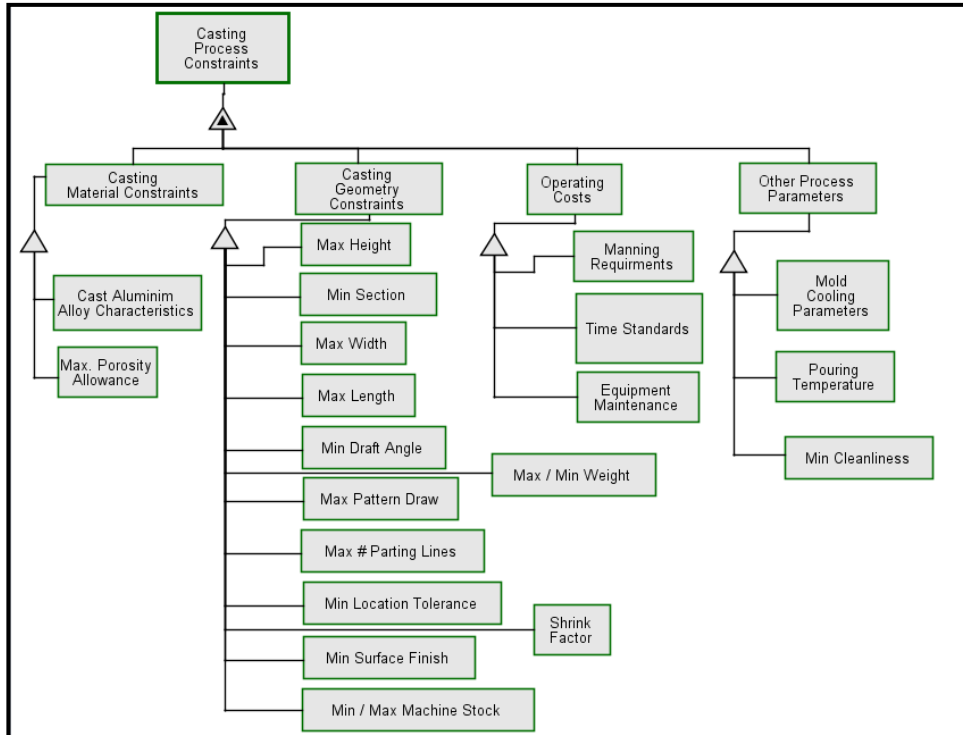

Figure A7.14: Casting Process Constraints

In addition, OPM enables the definition of equipment sets that are required to complete the process (Figures A7.15-16). While the equipment objects in the model can get down to the instance data for specific resource types, our process modeling approach will specify resources of a specific type, and we will rely on the agent system to interface with the MML for the selection of the specific resource instance that satisfies that resource type.

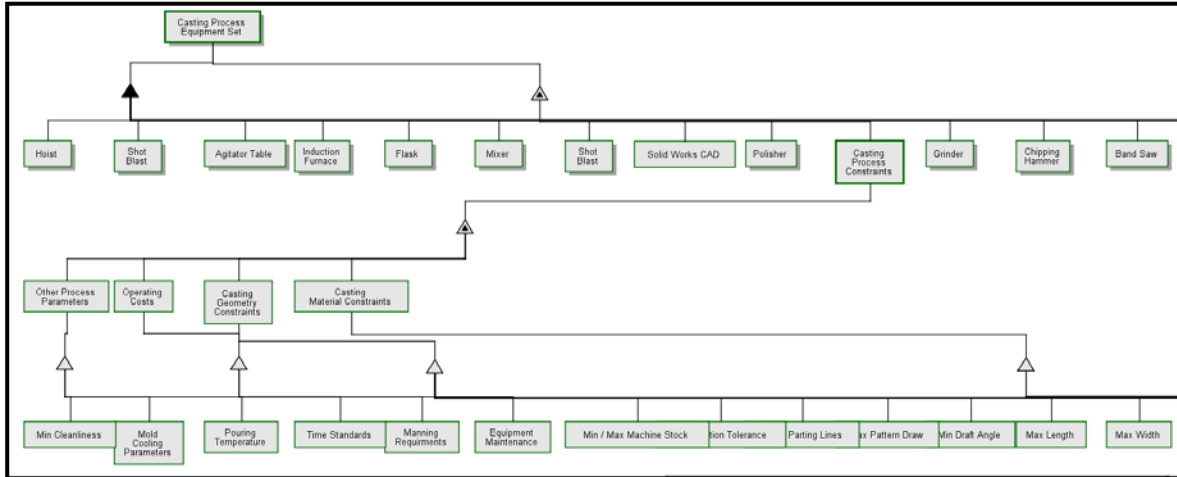

Figure A7.15: Casting Process Equipment Set

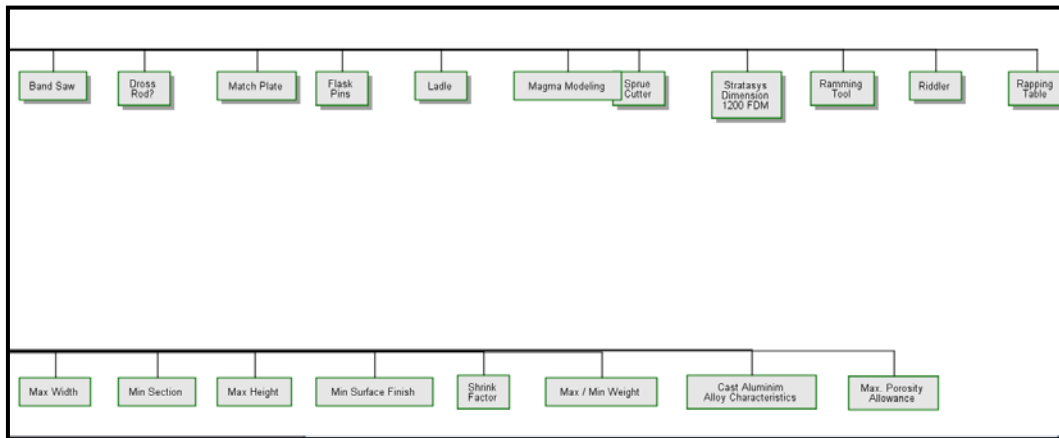
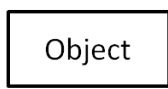

Figure A7.16: Casting Process Equipment Set (cont.)

Process Model Glossary

Main Entities



Physical (shadowed), Informational (i.e. data), or Environmental (dashed)



Resides within object (e.g., Mold object has states “Empty” or “Filled”)



Physical (shadowed), Informational, or Environmental (dashed)

Subprocesses definition possible within a process

Structural Relations (connection/association between 2 entities), 4 types



Aggregation – Participation (used to create members of an object class)



Generalization – Specification (extends inheritance concept to objects and processes)



Classification – Instantiation (connects objects to their instances)



Featuring – Characterization (represent connections between things and their features)

Potential interface to resources in MML

e.g., Process Constraints object connected to Process Equipment object

Procedural Links (connects a process to an enabler not changed by that process), 4 types

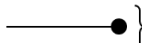

Agent Link (connect intelligent enablers (e.g., humans) and the process they enable)

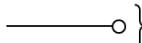

Instrument Link (connect non-intelligent enablers (e.g., machines, data) and the process they enable)

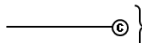

Condition Link (connects processes with object states, i.e., execute process if and only if connected object is in certain state)

Figure A7.17: OPCAT OPM Process Model Glossary of Object, Relation, and Link Symbols

APPENDIX 8:
OPEN SOURCE LICENSE FOR AVM SOFTWARE, MODELS, AND DATA

Copyright (c) <year>, <copyright holder>.

Developed with the sponsorship of the Defense Advanced Research Projects Agency (DARPA) and delivered to the U.S. Government with Unlimited Rights as defined in DFARS 252.227-7013.

Permission is hereby granted, free of charge, to any person obtaining a copy of this data, including any software or models in source or binary form, specifications, algorithms, and documentation (collectively "the Data"), to deal in the Data without restriction, including without limitation the rights to use, copy, modify, merge, publish, distribute, sublicense, and/or sell copies of the Data, and to permit persons to whom the Data is furnished to do so, subject to the following conditions:

The above copyright notice and this permission notice shall be included in all copies or substantial portions of the Data.

THE DATA IS PROVIDED "AS IS", WITHOUT WARRANTY OF ANY KIND, EXPRESS OR IMPLIED, INCLUDING BUT NOT LIMITED TO THE WARRANTIES OF MERCHANTABILITY, FITNESS FOR A PARTICULAR PURPOSE AND NONINFRINGEMENT. IN NO EVENT SHALL THE AUTHORS, SPONSORS, DEVELOPERS, CONTRIBUTORS, OR COPYRIGHT HOLDERS BE LIABLE FOR ANY CLAIM, DAMAGES OR OTHER LIABILITY, WHETHER IN AN ACTION OF CONTRACT, TORT OR OTHERWISE, ARISING FROM, OUT OF OR IN CONNECTION WITH THE DATA OR THE USE OR OTHER DEALINGS IN THE DATA.